

FUEL SYSTEM—3.1L DIESEL ENGINE

CONTENTS

	page	page
GENERAL INFORMATION	1	
FUEL DELIVERY SYSTEM— 3.1L DIESEL ENGINE.....	2	
FUEL INJECTION SYSTEM— 3.1L DIESEL ENGINE.....		21

GENERAL INFORMATION

INDEX

	page	page
GENERAL INFORMATION		
FUEL REQUIREMENTS—3.1L DIESEL.....	1	
FUEL SHUTDOWN SOLENOID		1

GENERAL INFORMATION

FUEL SHUTDOWN SOLENOID

The fuel shutdown solenoid is controlled and operated by the ECM.

The fuel shutdown (shut-off) solenoid is used to electrically shut off the diesel fuel supply to the high-pressure fuel injection pump. The solenoid is mounted to the rear of the injection pump.

The solenoid controls starting and stopping of the engine regardless of the position of the accelerator pedal. When the ignition (key) switch is OFF, the solenoid is shut off and fuel flow is not allowed to the fuel injection pump. When the key is placed in the ON or START positions, fuel supply is allowed at the injection pump.

FUEL REQUIREMENTS—3.1L DIESEL

Premium quality diesel fuel with a minimum Cetane rating of 50 or higher is required.

FUEL DELIVERY SYSTEM—3.1L DIESEL ENGINE

INDEX

	page		page
DESCRIPTION AND OPERATION			
FUEL DRAIN TUBES	6	FUEL INJECTOR TEST	9
FUEL FILTER/WATER SEPARATOR	3	FUEL SHUTDOWN SOLENOID TEST	11
FUEL GAUGE SENDING UNIT	3	FUEL SUPPLY RESTRICTIONS	10
FUEL HEATER	6	GENERAL INFORMATION	7
FUEL HEATER RELAY	7	HIGH-PRESSURE FUEL LINE LEAK TEST	11
FUEL INJECTION PUMP	3	VISUAL INSPECTION	7
FUEL INJECTORS	4	SERVICE PROCEDURES	
FUEL SHUTDOWN SOLENOID	3	AIR BLEED PROCEDURES	11
FUEL SYSTEM PRESSURE WARNING	2	FUEL INJECTION PUMP TIMING	12
FUEL TANK	2	REMOVAL AND INSTALLATION	
FUEL TANK MODULE	2	AIR CLEANER ELEMENT	12
FUEL TUBES/LINES/HOSES AND CLAMPS—		FUEL DRAIN TUBES	12
LOW-PRESSURE TYPE	5	FUEL FILTER/WATER SEPARATOR	12
HIGH-PRESSURE FUEL LINES	5	FUEL HEATER	13
INTRODUCTION	2	FUEL HEATER RELAY	14
QUICK-CONNECT FITTINGS—LOW		FUEL INJECTION PUMP	14
PRESSURE TYPE	5	FUEL INJECTORS	18
DIAGNOSIS AND TESTING		FUEL LEVEL SENSOR	14
AIR IN FUEL SYSTEM	9	HIGH-PRESSURE LINES	19
FUEL HEATER RELAY TEST	9	SPECIFICATIONS	
FUEL INJECTION PUMP TEST	10	FUEL INJECTOR FIRING SEQUENCE	20
FUEL INJECTOR / NEEDLE MOVEMENT		FUEL SYSTEM PRESSURE	20
SENSOR TEST	10	FUEL TANK CAPACITY	20
		IDLE SPEED	20

DESCRIPTION AND OPERATION

INTRODUCTION

This Fuel Delivery section will cover components not controlled by the PCM. For components controlled by the PCM, refer to the Fuel Injection System—3.1L Diesel Engine section of this group.

The fuel heater relay, fuel heater and fuel gauge are not operated by the PCM. These components are controlled by the ignition (key) switch. All other fuel system electrical components necessary to operate the engine are controlled or regulated by the PCM.

FUEL SYSTEM PRESSURE WARNING

WARNING: HIGH-PRESSURE FUEL LINES DELIVER DIESEL FUEL UNDER EXTREME PRESSURE FROM THE INJECTION PUMP TO THE FUEL INJECTORS. THIS MAY BE AS HIGH AS 45,000 KPA (6526 PSI). USE EXTREME CAUTION WHEN INSPECTING FOR HIGH-PRESSURE FUEL LEAKS. INSPECT FOR HIGH-PRESSURE FUEL LEAKS WITH A SHEET OF CARDBOARD (Fig. 1). HIGH FUEL INJECTION

PRESSURE CAN CAUSE PERSONAL INJURY IF CONTACT IS MADE WITH THE SKIN.

FUEL TANK

The fuel tank and tank mounting used with the diesel powered engine is the same as used with gasoline powered models, although the fuel tank module is different.

The fuel tank contains the fuel tank module and one rollover valve. Two fuel lines are routed to the fuel tank module. One line is used for fuel supply to the fuel filter/water separator. The other is used to return excess fuel back to the fuel tank.

The fuel tank module contains the fuel gauge electrical sending unit. **An electrical fuel pump is not used with the diesel engine.**

FUEL TANK MODULE

An electric fuel pump is not attached to the fuel tank module for diesel powered engines. Fuel is siphoned by the fuel injection pump.

DESCRIPTION AND OPERATION (Continued)

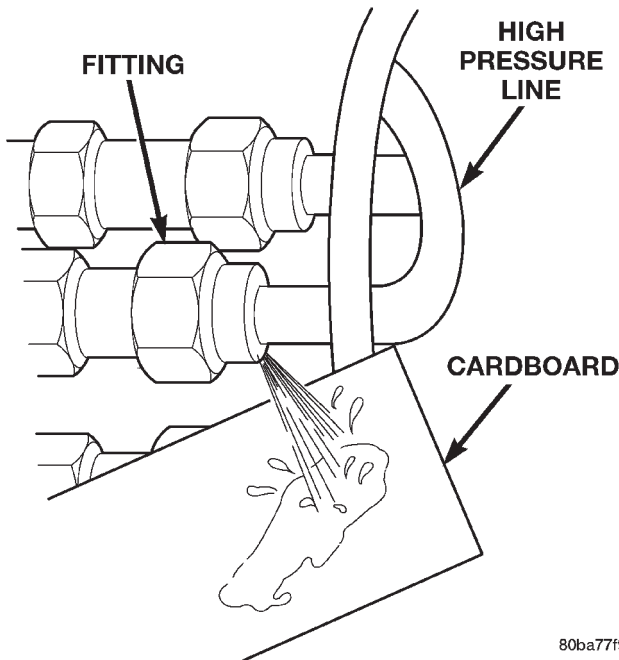

Fig. 1 Typical Fuel Pressure Test at Injection Pump

The fuel tank module is installed in the top of the fuel tank. The fuel tank module contains the following components:

- Fuel reservoir
- Electric fuel gauge sending unit
- Fuel supply line connection
- Fuel return line connection
- Wire harness

FUEL GAUGE SENDING UNIT

The fuel gauge sending unit is attached to the side of the fuel pump module. The sending unit consists of a float, an arm, and a variable resistor (track). The track is used to send an electrical signal used for fuel gauge operation.

As the fuel level increases, the float and arm move up. This decreases the sending unit resistance, causing the PCM to send a signal to the fuel gauge on the instrument panel to read full. As the fuel level decreases, the float and arm move down. This increases the sending unit resistance, causing the PCM to send a signal to the fuel gauge on the instrument panel to read empty.

FUEL FILTER/WATER SEPARATOR

The fuel filter/water separator is located in the engine compartment on the left side behind the generator (Fig. 2).

The combination fuel filter/water separator protects the fuel injection pump by helping to remove water and contaminants from the fuel. Moisture collects at the bottom of the filter/separator in a plastic bowl.

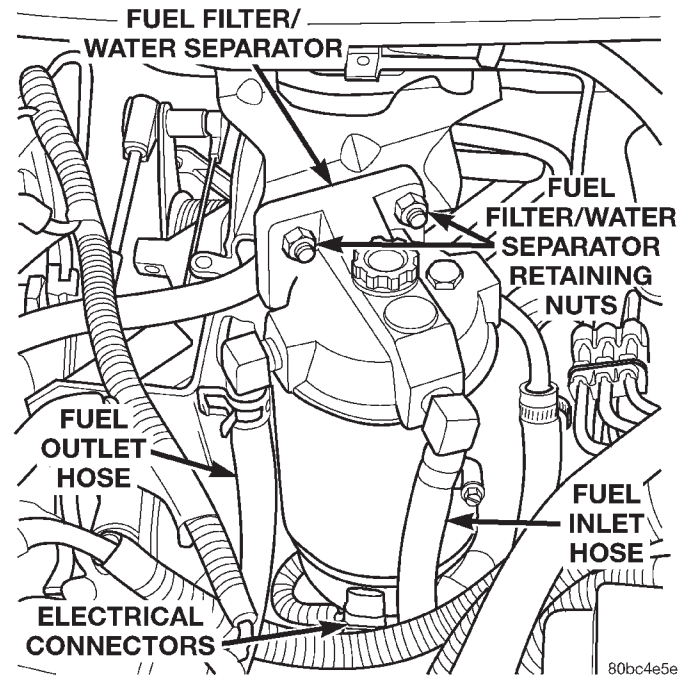

Fig. 2 Fuel Filter/Water Separator Location

The fuel filter/water separator assembly contains the fuel filter, fuel heater element, and fuel drain valve.

For information on the fuel heater, refer to Fuel Heater in this group.

Refer to the maintenance schedules in Group 0 in this manual for the recommended fuel filter replacement intervals.

For periodic draining of water from the bowl, refer to Fuel Filter/Water Separator Removal/Installation in this group.

FUEL SHUTDOWN SOLENOID

The fuel shutdown solenoid is controlled and operated by the ECM.

The fuel shutdown (shut-off) solenoid is used to electrically shut off the diesel fuel supply to the high-pressure fuel injection pump. The solenoid is mounted to the rear of the injection pump.

The solenoid controls starting and stopping of the engine regardless of the position of the accelerator pedal. When the ignition (key) switch is OFF, the solenoid is shut off and fuel flow is not allowed to the fuel injection pump. When the key is placed in the ON or START positions, fuel supply is allowed at the injection pump.

FUEL INJECTION PUMP

The fuel injection pump is a mechanical distributor-type, Bosch VP36 series (Fig. 3). A gear on the end of the injection pump shaft meshes with the drive gear at the front of engine. The pump is mechanically timed to the engine. The ECM can make adjustments to the timing of the injection pump.

DESCRIPTION AND OPERATION (Continued)

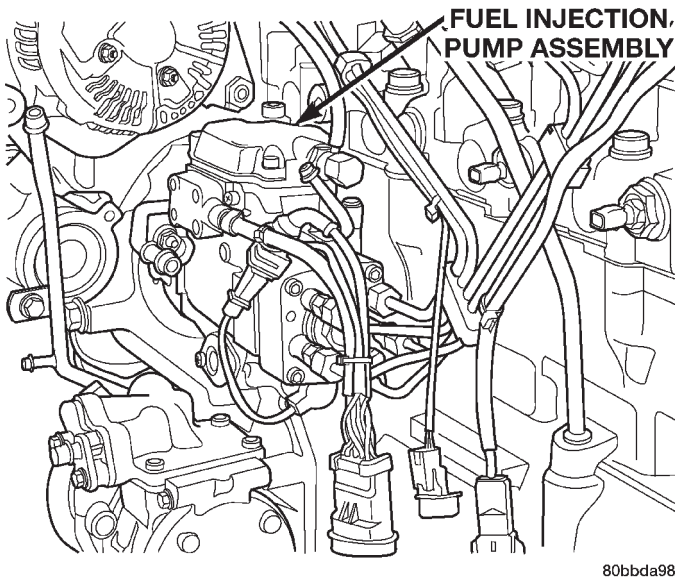

Fig. 3 Fuel Injection Pump

The injection pump contains the fuel shutdown solenoid, fuel temperature sensor, control sleeve sensor, fuel quantity actuator and the fuel timing solenoid (Fig. 3).

In the electronically controlled injection pump, the pump plunger works the same as the pump plunger in a mechanically controlled injection pump, but the amount of fuel and the time the fuel is injected is controlled by the vehicle's ECM, instead of by a mechanical governor assembly. A solenoid controlled by the ECM is used in place of the mechanical governor assembly, and it moves a control sleeve inside the pump that regulates the amount of fuel being injected. There is no mechanical connection between the accelerator pedal and the electronically controlled injection pump. Instead, a sensor connected to the accelerator pedal sends a signal to the ECM that represents the actual position of the accelerator pedal. The ECM uses this input, along with input from other sensors to move the control sleeve to deliver the appropriate amount of fuel. This system is known as "Drive-By-Wire"

The actual time that the fuel is delivered is very important to the diesel combustion process. The ECM monitors outputs from the engine speed sensor (flywheel position in degrees), and the fuel injector sensor (mechanical movement within the #1 cylinder fuel injector). Outputs from the Accelerator Pedal Position sensor, engine speed sensor (engine rpm) and engine coolant temperature sensor are also used. The ECM will then compare its set values to these outputs to electrically adjust the amount of fuel timing (amount of advance) within the injection pump. This is referred to as "Closed Loop" operation. The ECM monitors fuel timing by comparing its set value to when the injector #1 opens. If the value is greater than a preset value a fault will be set.

Actual electric fuel timing (amount of advance) is accomplished by the fuel timing solenoid mounted to the bottom of the injection pump (Fig. 3). Fuel timing will be adjusted by the ECM, which controls the fuel timing solenoid.

An overflow valve is attached into the fuel return line at the rear of the fuel injection pump (Fig. 3). This valve serves two purposes. One is to ensure that a certain amount of residual pressure is maintained within the pump when the engine is switched off. This will prevent the fuel timing mechanism within the injection pump from returning to its zero position. The other purpose is to allow excess fuel to be returned to the fuel tank through the fuel return line. The pressure values within this valve are preset and can not be adjusted.

The fuel injection pump supplies high-pressure fuel of approximately 45,000 kPa (6526 psi) to each injector in precise metered amounts at the correct time.

For mechanical injection pump timing, refer to Fuel Injection Pump Timing in the Service Procedures section of this group.

FUEL INJECTORS

Fuel drain tubes (Fig. 4) are used to route excess fuel back to the overflow valve at the rear of the injection pump. This excess fuel is then returned to the fuel tank through the fuel return line.

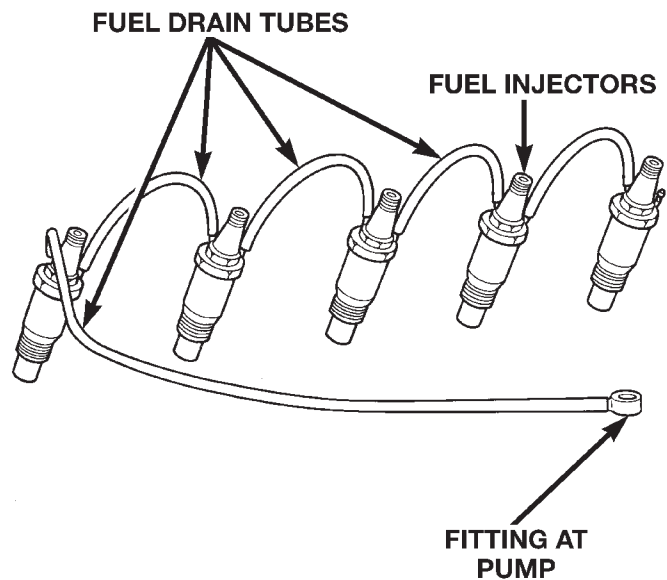

Fig. 4 Fuel Injectors and Drain Tubes

The injectors are connected to the fuel injection pump by the high-pressure fuel lines. A separate injector is used for each of the five cylinders. An injector containing a sensor (Fig. 5) is used on the

80bc4ed1

DESCRIPTION AND OPERATION (Continued)

cylinder number one injector. This injector is called instrumented injector #1 or needle movement sensor. It is used to tell the ECM when the #1 injector's internal spring-loaded valve seat has been forced open by pressurized fuel being delivered to the cylinder, which is at the end of its compression stroke. When the instrumented injector's valve seat is force open, it sends a small voltage spike pulse to the ECM. This tells the ECM that cylinder #1 is firing. It is not used with the other four injectors.

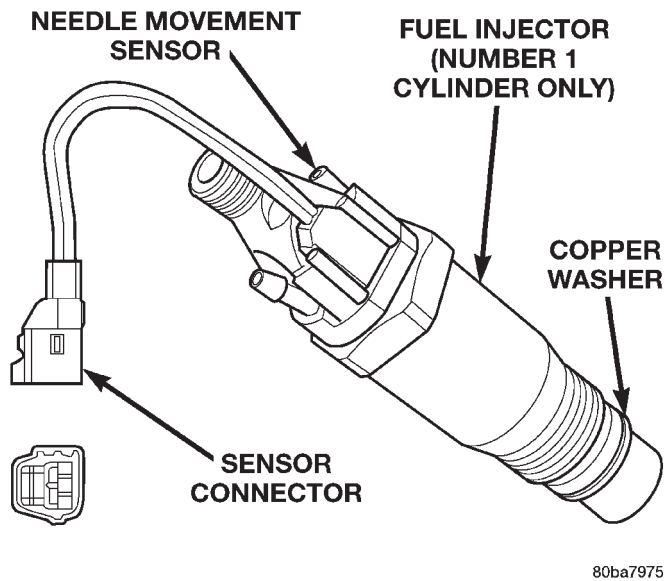

Fig. 5 Fuel Injector Sensor

Fuel enters the injector at the fuel inlet (top of injector) and is routed to the needle valve bore. When fuel pressure rises to approximately 15,000–15,800 kPa (2175–2291 psi), the needle valve spring tension is overcome. The needle valve rises and fuel flows through the spray holes in the nozzle tip into the combustion chamber. The pressure required to lift the needle valve is the injector opening pressure setting. This is referred to as the “pop-off” pressure setting.

Fuel pressure in the injector circuit decreases after injection. The injector needle valve is immediately closed by the needle valve spring and fuel flow into the combustion chamber is stopped. Exhaust gases are prevented from entering the injector nozzle by the needle valve.

A copper washer (gasket) is used at the base of each injector (Fig. 5) to prevent combustion gases from escaping.

Fuel injector firing sequence is 1–2–4–5–3.

FUEL TUBES/LINES/HOSES AND CLAMPS—LOW-PRESSURE TYPE

Also refer to the proceeding section on Quick-Connect Fittings.

Inspect all hose connections such as clamps, couplings and fittings to make sure they are secure and leaks are not present. The component should be replaced immediately if there is any evidence of degradation that could result in failure.

Never attempt to repair a plastic fuel line/tube or a quick-connect fitting. Replace complete line/tube as necessary.

Avoid contact of any fuel tubes/hoses with other vehicle components that could cause abrasions or scuffing. Be sure that the fuel lines/tubes are properly routed to prevent pinching and to avoid heat sources.

The lines/tubes/hoses are of a special construction. If it is necessary to replace these lines/tubes/hoses, use only original equipment type.

The hose clamps used to secure the rubber hoses are of a special rolled edge construction. This construction is used to prevent the edge of the clamp from cutting into the hose. Only these rolled edge type clamps may be used in this system. All other types of clamps may cut into the hoses and cause fuel leaks.

Where a rubber hose is joined to a metal tube (staked), do not attempt to repair. Replace entire line/tube assembly.

Use new original equipment type hose clamps. Tighten hose clamps to 2 N·m (20 in. lbs.) torque.

QUICK-CONNECT FITTINGS—LOW PRESSURE TYPE

Different types of quick-connect fittings are used to attach various fuel system components. These are: a single-tab type, a two-tab type or a plastic retainer ring type (Fig. 6). Refer to Quick-Connect Fittings in the Removal/Installation section for more information.

CAUTION: The interior components (o-rings, spacers) of quick-connect fitting are not serviced separately, but new pull tabs are available for some types. Do not attempt to repair damaged fittings or fuel lines/tubes. If repair is necessary, replace the complete fuel tube assembly.

HIGH-PRESSURE FUEL LINES

CAUTION: The high-pressure fuel lines must be held securely in place in their holders. The lines cannot contact each other or other components. Do not attempt to weld high-pressure fuel lines or to repair lines that are damaged. Only use the recommended lines when replacement of high-pressure fuel line is necessary.

DESCRIPTION AND OPERATION (Continued)

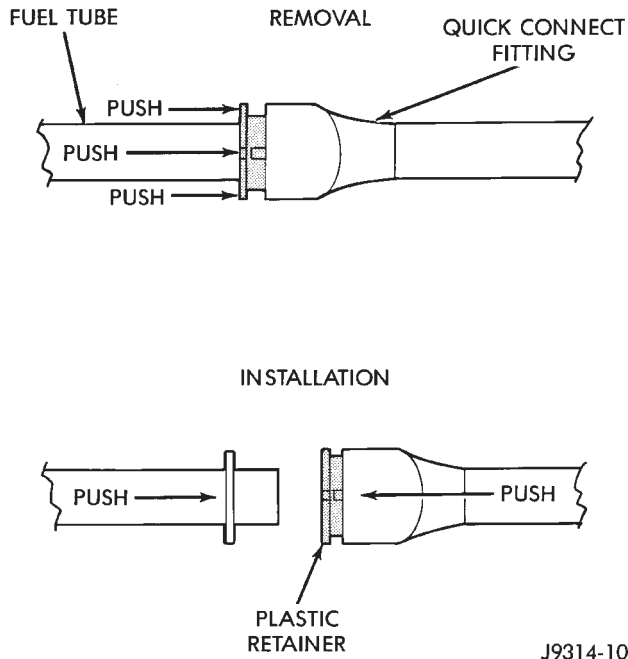

J9314-100

Fig. 6 Plastic Retainer Ring-Type Fitting

High-pressure fuel lines deliver fuel under pressure of up to approximately 45,000 kPa (6526 PSI) from the injection pump to the fuel injectors. The lines expand and contract from the high-pressure fuel pulses generated during the injection process. All high-pressure fuel lines are of the same length and inside diameter. Correct high-pressure fuel line usage and installation is critical to smooth engine operation.

WARNING: USE EXTREME CAUTION WHEN INSPECTING FOR HIGH-PRESSURE FUEL LEAKS. INSPECT FOR HIGH-PRESSURE FUEL LEAKS WITH A SHEET OF CARDBOARD. HIGH FUEL INJECTION PRESSURE CAN CAUSE PERSONAL INJURY IF CONTACT IS MADE WITH THE SKIN.

FUEL DRAIN TUBES

These rubber tubes are low-pressure type.

Some excess fuel is continually vented from the fuel injection pump. During injection, a small amount of fuel flows past the injector nozzle and is not injected into the combustion chamber. This fuel drains into the fuel drain tubes (Fig. 7) and back to the tee banjo fitting, which is connected to the same line as the overflow valve, which allows a variable quantity to return to the fuel tank. The overflow valve is calibrated to open at a preset pressure. Excess fuel not required by the pump to maintain the minimum pump cavity pressure is then returned through the overflow valve and on to the fuel tank through the fuel return line.

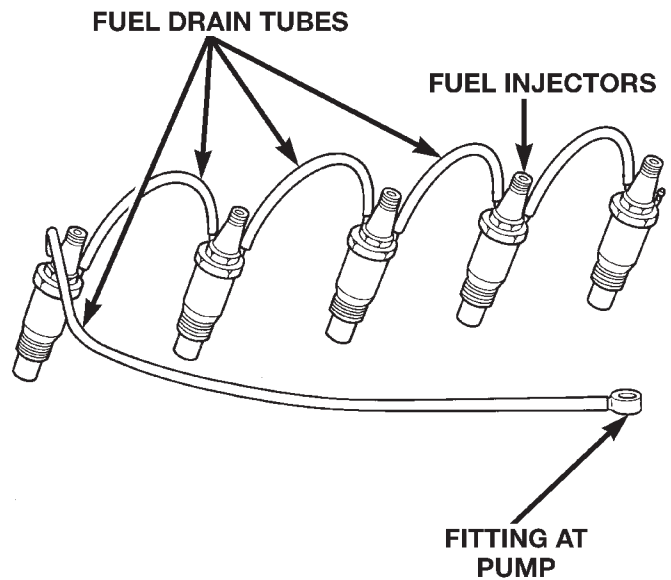

80bc4ed1

Fig. 7 Fuel Drain Tubes**FUEL HEATER**

The fuel heater is used to prevent diesel fuel from waxing during cold weather operation. The fuel heater is located in the bottom plastic bowl of the fuel filter/water separator (Fig. 8).

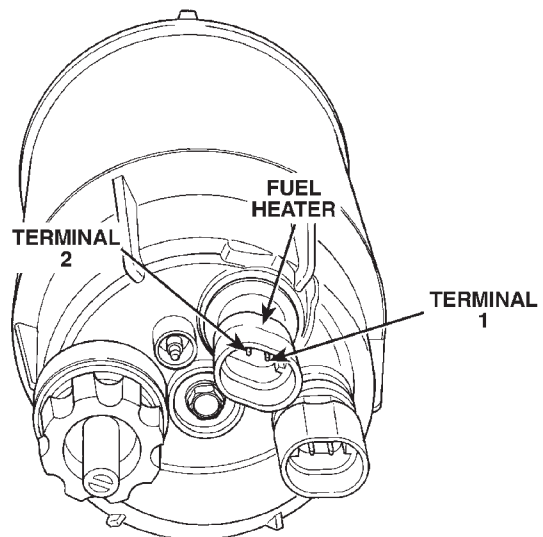

80b6b14f

Fig. 8 Fuel Heater Temperature Sensor and Element Location

The element inside the heater assembly is made of a Positive Temperature Coefficient (PTC) material, and has power applied to it by the fuel heater relay anytime the ignition key is in the "on" position. PTC material has a high resistance to current flow when its temperature is high, which means that it will not

DESCRIPTION AND OPERATION (Continued)

generate heat when the temperature is above a certain value. When the temperature is below 7°C (45° F), the resistance of the PTC element is lowered, and allows current to flow through the fuel heater element warming the fuel. When the temperature is above 29°C (85° F), the PTC element's resistance rises, and current flow through the heater element stops.

Voltage to operate the fuel heater is supplied from the ignition (key) switch and through the fuel heater relay. Refer to the following Fuel Heater Relay for additional information. **The fuel heater and fuel heater relay are not controlled by the Powertrain Control Module (PCM).**

Current draw for the heater element is 150 watts at 14 volts (DC).

FUEL HEATER RELAY

Voltage to operate the fuel heater is supplied from the ignition (key) switch through the fuel heater relay. **The PCM or ECM is not used to control this relay.**

The fuel heater relay is located in the PDC. The PDC is located next to the battery in the engine compartment. For the location of the relay within the PDC, refer to label on PDC cover.

DIAGNOSIS AND TESTING

GENERAL INFORMATION

This section of the group will cover a general diagnosis of diesel engine fuel system components.

Diagnostic Trouble Codes: Refer to On-Board Diagnostics in Group 25, Emission Control System for a list of Diagnostic Trouble Codes (DTC's) for certain fuel system components.

VISUAL INSPECTION

A visual inspection for loose, disconnected, or incorrectly routed wires and hoses should be made before attempting to diagnose or service the diesel fuel injection system. A visual check will help find these conditions. It also saves unnecessary test and diagnostic time. A thorough visual inspection of the fuel injection system includes the following checks:

- (1) Be sure that the battery connections are tight and not corroded.
- (2) Be sure that the 60 way connector is fully engaged with the PCM.
- (3) Be sure that the 68 way connector is fully engaged with the ECM.
- (4) Verify that the electrical connections for the ASD relay are clean and free of corrosion. This relay is located in the PDC. For the location of the relay within the PDC, refer to label on PDC cover.

- (5) Verify that the electrical connections for the fuel heater relay are clean and free of corrosion. This relay is located in the PDC. For the location of the relay within the PDC, refer to label on PDC cover.

- (6) Be sure the electrical connectors at the ends of the glow plugs (Fig. 9) are tight and free of corrosion.

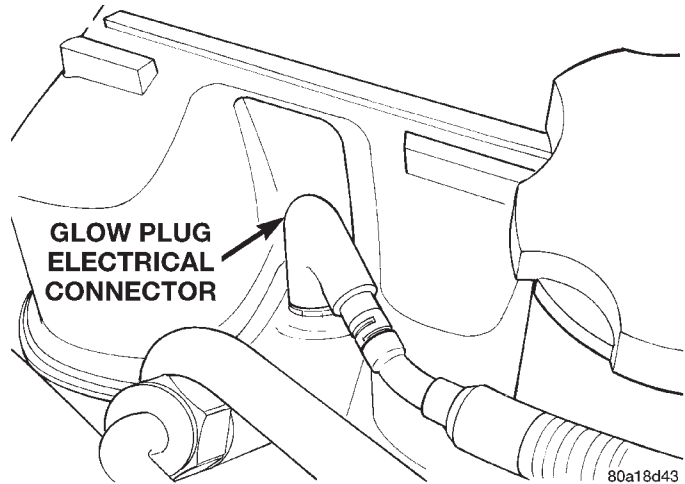

Fig. 9 Glow Plug Connector

- (7) Be sure that the electrical connections at the glow plug relay are tight and not corroded. The glow plug relay is located in the engine compartment on the left-inner fender (Fig. 10) (Fig. 11).

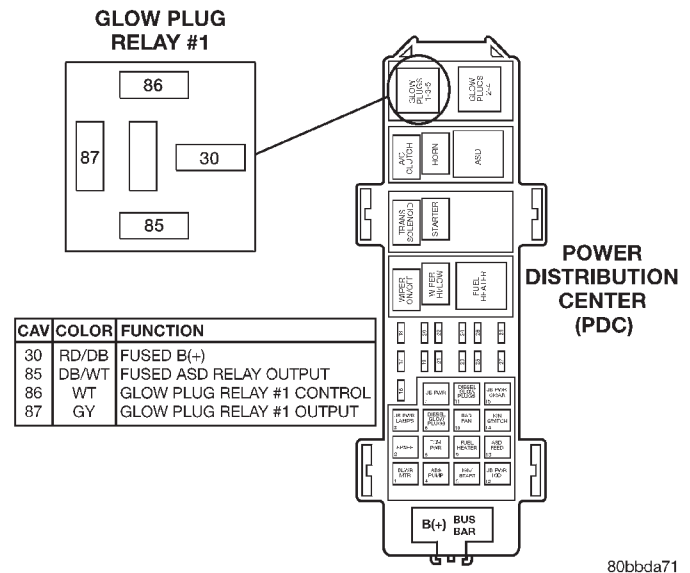

Fig. 10 Glow Plug Relay #1 Location

- (8) Inspect the starter motor and starter solenoid connections for tightness and corrosion.
- (9) Verify that the Fuel Injection Pump electrical connector is firmly connected. Inspect the connector for corrosion or damaged wires.
- (10) Verify that the fuel heater electrical connector is firmly attached to the filter bowl at the bottom of

DIAGNOSIS AND TESTING (Continued)

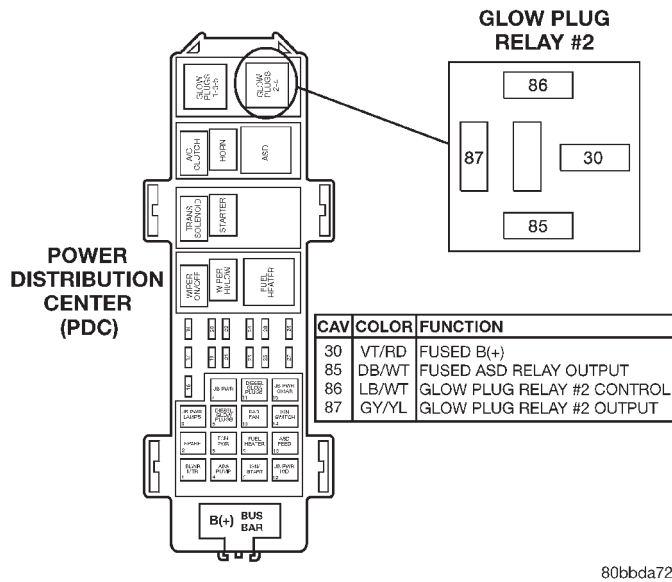

Fig. 11 Glow Plug Relay #2 Location

the fuel filter/water separator. Inspect the connector for corrosion or damaged wires.

(11) Verify that the electrical pigtail connector (sensor connector) (Fig. 12) for the fuel injector sensor is firmly connected to the engine wiring harness. Inspect the connector for corrosion or damaged wires. This sensor is used on the #1 cylinder injector only.

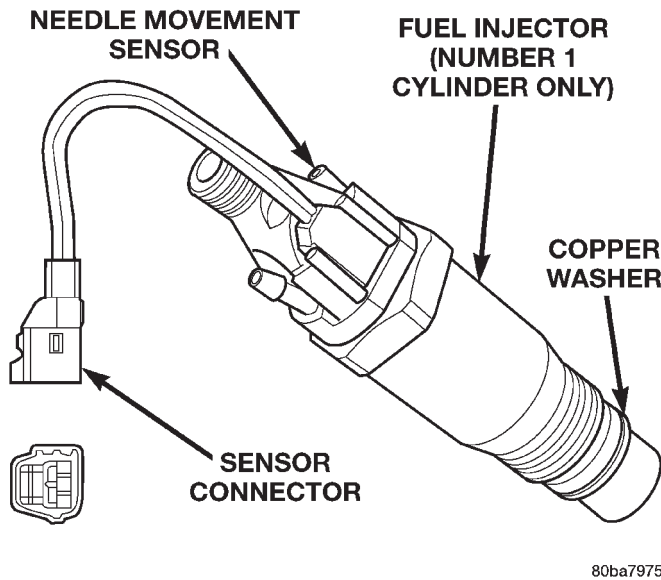

Fig. 12 Fuel Injector Sensor

(12) Inspect for exhaust system restrictions such as pinched exhaust pipes or a collapsed or plugged muffler.

(13) Verify turbocharger wastegate operation. Refer to Group 11, Exhaust System and Turbocharger Group for information.

(14) Verify that the harness connector is firmly connected to the engine coolant temperature sensors.

The (PCM) E.C.T. sensor is located on the side of cylinder head near the rear of fuel injection pump (Fig. 13). The (ECM) E.C.T. sensor is located on the side of the cylinder head just to the rear of the PCM sensor (Fig. 13).

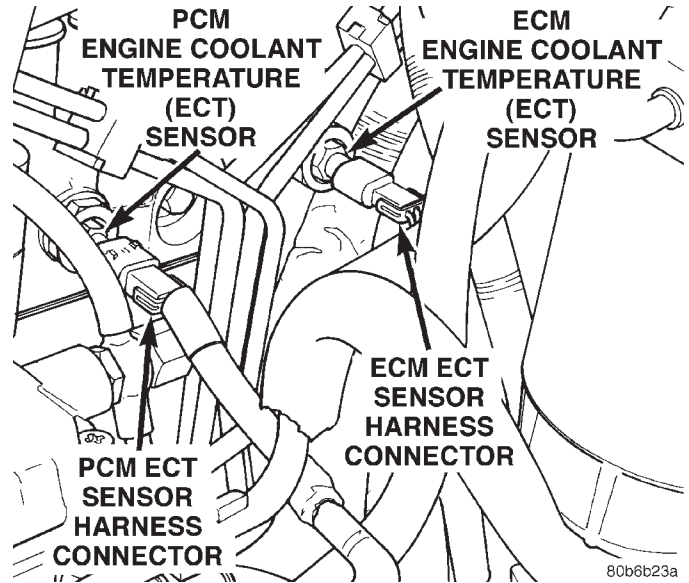

Fig. 13 Engine Coolant Temperature Sensor Locations

(15) Check for air in the fuel system. Refer to the Air Bleed Procedure.

(16) Inspect all fuel supply and return lines for signs of leakage.

(17) Be sure that the ground connections are tight and free of corrosion. Refer to Group 8, Wiring for locations of ground connections.

(18) Inspect the air cleaner element (filter) for restrictions.

(19) Be sure that the turbocharger output hose is properly connected to the charge air cooler (intercooler) inlet tube. Verify that the charge air cooler output hose is properly connected to the cooler and the intake manifold. Refer to Group 11, Exhaust System and Turbocharger for information.

(20) Be sure that the vacuum hoses to the vacuum pump are connected and not leaking. The vacuum pump is located in the front of engine (internal) and is driven from the crankshaft gear (Fig. 14). Disconnect the hose and check for minimum vacuum from the pump. Refer to Group 5, Brake System for specifications and procedures.

(21) Be sure that the accessory drive belt is not damaged or slipping.

(22) Verify there is a good connection at the engine speed sensor. Refer to the Fuel Injection System in this section for location of the engine speed sensor location.

DIAGNOSIS AND TESTING (Continued)

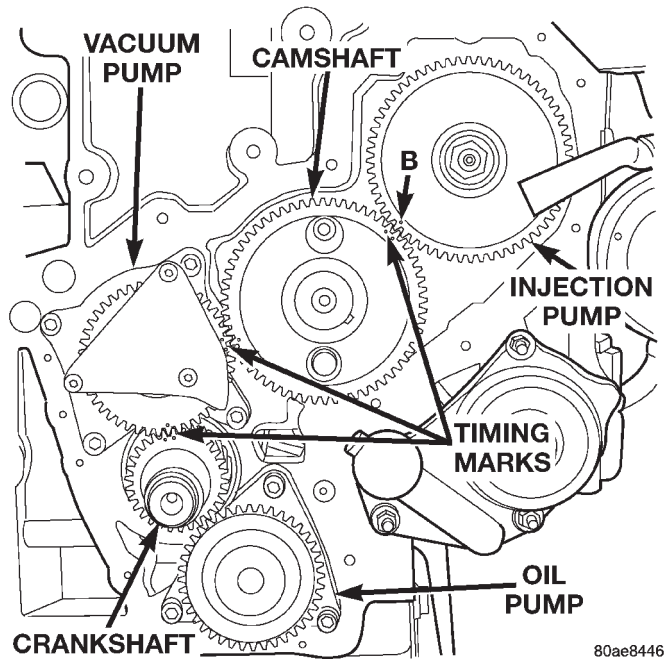

Fig. 14 Vacuum Pump at Front of Engine

(23) Verify there is a good connection at the Boost Pressure Sensor, which is a part of the air intake assembly.

AIR IN FUEL SYSTEM

Air will enter the fuel system whenever the fuel supply lines, fuel filter/water separator, fuel filter bowl, injection pump, high-pressure lines or injectors are removed or disconnected. Air will also enter the fuel system whenever the fuel tank has been run empty.

Air trapped in the fuel system can result in hard starting, a rough running engine, engine misfire, low power, excessive smoke and fuel knock. After service is performed, air must be bled from the system before starting the engine.

Inspect the fuel system from the fuel tank to the injectors for loose connections. Leaking fuel is an indicator of loose connections or defective seals. Air can also enter the fuel system between the fuel tank and the injection pump. Inspect the fuel tank and fuel lines for damage that might allow air into the system.

For air bleeding, refer to Air Bleed Procedure in the Service Procedures section of this group.

FUEL HEATER RELAY TEST

The fuel heater relay is located in the Power Distribution Center (PDC). Refer to Relays—Operation/Testing in Fuel Injection System section of this group for test procedures.

FUEL INJECTOR TEST

The fuel injection nozzles, located on the engine cylinder head, spray fuel under high pressure into the individual combustion chambers. Pressurized fuel, delivered by the fuel injection pump, unseats a spring-loaded needle valve inside the injector, and the fuel is atomized as it escapes through the injector opening into the engine's combustion chamber. If the fuel injector does not operate properly, the engine may misfire, or cause other driveability problems.

A leak in the injection pump-to-injector high-pressure fuel line can cause many of the same symptoms as a malfunctioning injector. Inspect for a leak in the high-pressure lines before checking for a malfunctioning fuel injector.

WARNING: THE INJECTION PUMP SUPPLIES HIGH-PRESSURE FUEL OF UP TO APPROXIMATELY 45,000 KPA (6526 PSI) TO EACH INDIVIDUAL INJECTOR THROUGH THE HIGH-PRESSURE LINES. FUEL UNDER THIS AMOUNT OF PRESSURE CAN PENETRATE THE SKIN AND CAUSE PERSONAL INJURY. WEAR SAFETY GOGGLES AND ADEQUATE PROTECTIVE CLOTHING. AVOID CONTACT WITH FUEL SPRAY WHEN BLEEDING HIGH-PRESSURE FUEL LINES.

WARNING: DO NOT BLEED AIR FROM THE FUEL SYSTEM OF A HOT ENGINE. DO NOT ALLOW FUEL TO SPRAY ONTO THE EXHAUST MANIFOLD WHEN BLEEDING AIR FROM THE FUEL SYSTEM.

To determine which fuel injector is malfunctioning, run the engine and loosen the high-pressure fuel line nut at the injector (Fig. 15). Listen for a change in engine speed. If engine speed drops, the injector was operating normally. If engine speed remains the same, the injector may be malfunctioning. After testing, tighten the line nut to 30 N·m (22 ft. lbs.) torque. Test all injectors in the same manner one at a time.

Once an injector has been found to be malfunctioning, remove it from the engine and test it. Refer to the Removal/Installation section of this group for procedures.

After the injector has been removed, install it to a bench-mount injector tester. Refer to operating instructions supplied with tester for procedures.

The opening pressure or "pop" pressure should be 15,000–15,800 kPa (2175–2291 psi). If the fuel injector needle valve is opening ("popping") too early or too late, replace the injector.

DIAGNOSIS AND TESTING (Continued)

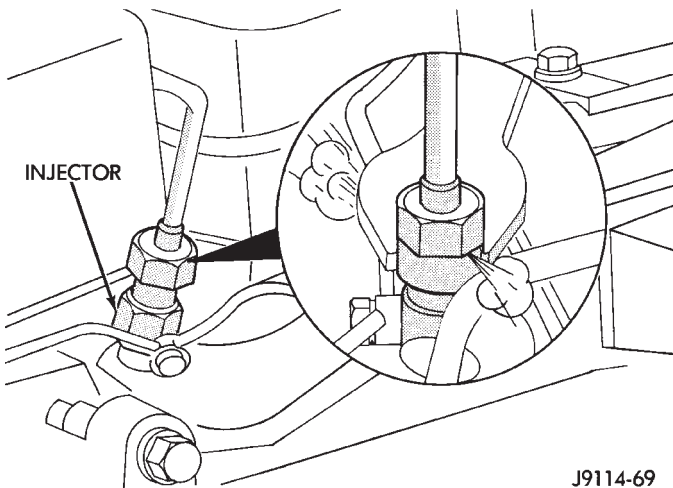

J9114-69

Fig. 15 Typical Inspection of Fuel Injector

FUEL INJECTOR / NEEDLE MOVEMENT SENSOR TEST

The needle movement sensor is used only on the number-1 cylinder fuel injector (Fig. 16). It is not used on the injectors for cylinders number 2, 3, 4 or 5.

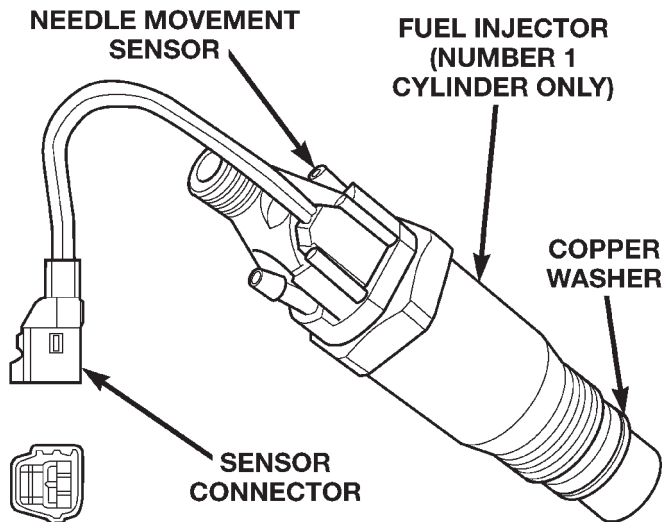

80ba7975

Fig. 16 Needle Movement Sensor Location

Testing the needle movement sensor requires the use of a DRB Scan tool. Refer to the Powertrain Diagnostic Procedures manual for additional information.

FUEL INJECTION PUMP TEST

The injection pump is not to be serviced or the warranty may be voided. If the injection pump requires service, the complete assembly must be replaced.

Incorrect injection pump timing (mechanical or electrical) can cause poor performance, excessive smoke and emissions and poor fuel economy.

A defective fuel injection pump, defective fuel timing solenoid or misadjusted mechanical pump timing can cause starting problems or prevent the engine from revving up. It can also cause:

- Engine surge at idle
- Rough idle (warm engine)
- Low power
- Excessive fuel consumption
- Poor performance
- Low power
- Black smoke from the exhaust
- Blue or white fog like exhaust
- Incorrect idle or maximum speed

The electronically controlled fuel pump has no mechanical governor like older mechanically controlled fuel pumps. Do not remove the top cover of the fuel pump, or the screws fastening the wiring pigtail to the side of the pump. **The warranty of the injection pump and the engine may be void if those seals have been removed or tampered with.**

FUEL SUPPLY RESTRICTIONS

LOW-PRESSURE LINES

Restricted or Plugged supply lines or fuel filter can cause a timing fault that will cause the ECM to operate the engine in a "Limp Home" mode. See the introduction of the Fuel Injection System in this group for more information on the Limp Home mode. Fuel supply line restrictions can cause starting problems and prevent the engine from revving up. The starting problems include; low power and blue or white fog like exhaust. Test all fuel supply lines for restrictions or blockage. Flush or replace as necessary. Bleed the fuel system of air once a fuel supply line has been replaced. Refer to the Air Bleed Procedure section of this group for procedures.

HIGH-PRESSURE LINES

Restricted (kinked or bent) high-pressure lines can cause starting problems, poor engine performance and black smoke from exhaust.

Examine all high-pressure lines for any damage. Each radius on each high-pressure line must be smooth and free of any bends or kinks.

Replace damaged, restricted or leaking high-pressure fuel lines with the correct replacement line.

CAUTION: The high-pressure fuel lines must be clamped securely in place in the holders. The lines cannot contact each other or other components. Do not attempt to weld high-pressure fuel lines or to repair lines that are damaged. Only use the recommended lines when replacement of high-pressure fuel line is necessary.

DIAGNOSIS AND TESTING (Continued)

FUEL SHUTDOWN SOLENOID TEST

Refer to the 3.1L Diesel Powertrain Diagnostic Manual for the Fuel Shutdown Solenoid test.

HIGH-PRESSURE FUEL LINE LEAK TEST

High-pressure fuel line leaks can cause starting problems and poor engine performance.

WARNING: DUE TO EXTREME FUEL PRESSURES OF UP TO 45,000 KPA (6526 PSI), USE EXTREME CAUTION WHEN INSPECTING FOR HIGH-PRESSURE FUEL LEAKS. DO NOT GET YOUR HAND, OR ANY PART OF YOUR BODY NEAR A SUSPECTED LEAK. INSPECT FOR HIGH-PRESSURE FUEL LEAKS WITH A SHEET OF CARDBOARD. HIGH FUEL INJECTION PRESSURE CAN CAUSE PERSONAL INJURY IF CONTACT IS MADE WITH THE SKIN.

Start the engine. Move the cardboard over the high-pressure fuel lines and check for fuel spray onto the cardboard (Fig. 17). If a high-pressure line connection is leaking, bleed the system and tighten the connection. Refer to the Air Bleed Procedure in this group for procedures. Replace damaged, restricted or leaking high-pressure fuel lines with the correct replacement line.

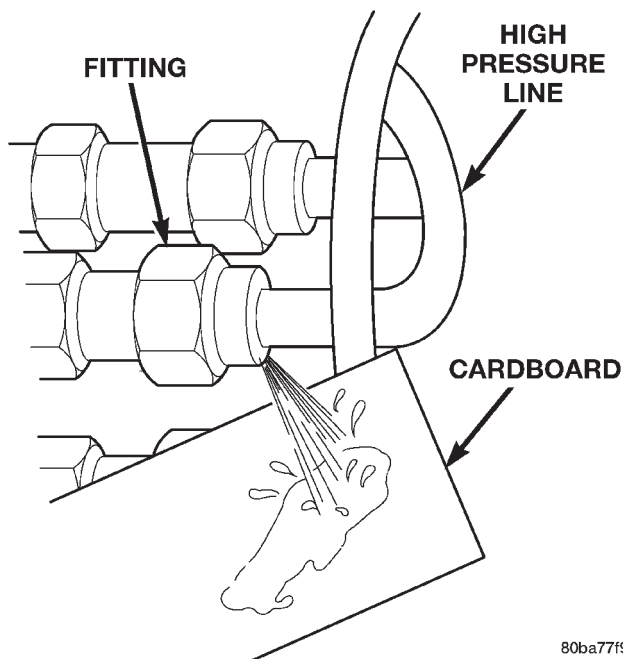

Fig. 17 Typical Fuel Pressure Test at Injection Pump

CAUTION: The high-pressure fuel lines must be clamped securely in the holders. The lines cannot contact each other or other components. Do not attempt to weld high-pressure fuel lines or to repair lines that are damaged. Only use the recommended

lines when replacement of high-pressure fuel line is necessary.

SERVICE PROCEDURES

AIR BLEED PROCEDURES**AIR BLEEDING AT FUEL FILTER**

A certain amount of air may become trapped in the fuel system when fuel system components are serviced or replaced. Bleed the system as needed after fuel system service according to the following procedures.

WARNING: DO NOT BLEED AIR FROM THE FUEL SYSTEM OF A HOT ENGINE. DO NOT ALLOW FUEL TO SPRAY ONTO THE EXHAUST MANIFOLD WHEN BLEEDING AIR FROM THE FUEL SYSTEM.

Some air enters the fuel system when the fuel filter or injection pump supply line is changed. This small amount of air is vented automatically from the injection pump through the fuel drain manifold tubes if the filter was changed according to instructions. Ensure the bowl of the fuel filter/water separator is full of fuel

It may be necessary to manually bleed the system if:

- The bowl of the fuel filter/water separator is not partially filled before installation of a new filter
- The injection pump is replaced
- High-pressure fuel line connections are loosened or lines replaced
- Initial engine start-up or start-up after an extended period of no engine operation
- Running fuel tank empty

FUEL INJECTION PUMP BLEEDING

(1) If the fuel injection pump has been replaced, air should be bled at the overflow valve before attempting to start engine.

- (a) Loosen the overflow valve (Fig. 18) at the rear of the injection pump.
- (b) Place a towel below the valve.

WARNING: WHEN CRANKING THE ENGINE TO BLEED AIR FROM THE INJECTION PUMP, THE ENGINE MAY START. PLACE THE TRANSMISSION IN NEUTRAL OR PARK AND SET PARKING BRAKE BEFORE ENGAGING THE STARTER MOTOR.

CAUTION: Do not engage the starter motor for more than 30 seconds at a time. Allow 2 minutes between cranking intervals.

SERVICE PROCEDURES (Continued)

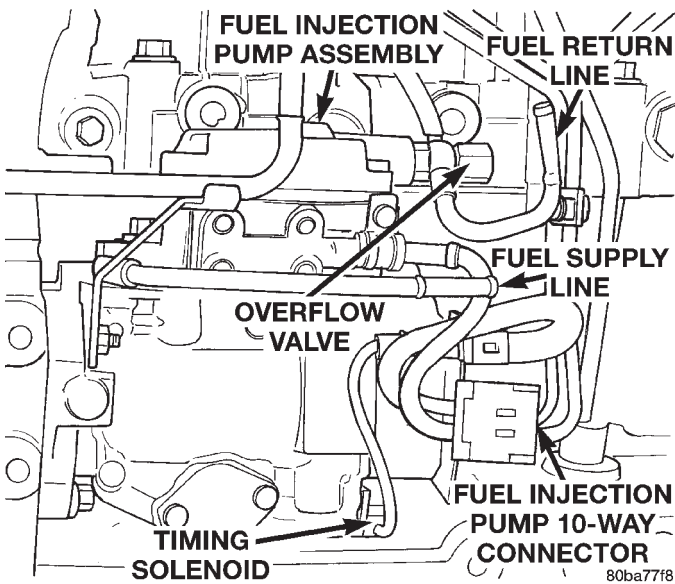

Fig. 18 Overflow Valve

(2) Crank the engine for 30 seconds at a time to allow air trapped in the injection pump to vent out the fuel injector drain tubes. Continue this procedure until the engine starts. Observe the previous WARNING and CAUTION.

(3) Tighten overflow valve.

HIGH-PRESSURE FUEL LINE BLEEDING

WARNING: THE INJECTION PUMP SUPPLIES HIGH-PRESSURE FUEL OF APPROXIMATELY 59,000 KPA (8,557 PSI) TO EACH INDIVIDUAL INJECTOR THROUGH THE HIGH-PRESSURE LINES. FUEL UNDER THIS AMOUNT OF PRESSURE CAN PENETRATE THE SKIN AND CAUSE PERSONAL INJURY. WEAR SAFETY GOGGLES AND ADEQUATE PROTECTIVE CLOTHING AND AVOID CONTACT WITH FUEL SPRAY WHEN BLEEDING HIGH-PRESSURE FUEL LINES.

WARNING: DO NOT BLEED AIR FROM THE FUEL SYSTEM OF A HOT ENGINE. DO NOT ALLOW FUEL TO SPRAY ONTO THE EXHAUST MANIFOLD WHEN BLEEDING AIR FROM THE FUEL SYSTEM.

Bleed air from one injector at time.

(1) Loosen the high-pressure fuel line fitting at the injector (Fig. 19).

(2) Crank the engine until all air has been bled from the line. **Do not operate the starter motor for longer than 30 seconds. Wait 2 minutes between cranking intervals.**

(3) Start the engine and bleed one injector at a time until the engine runs smoothly.

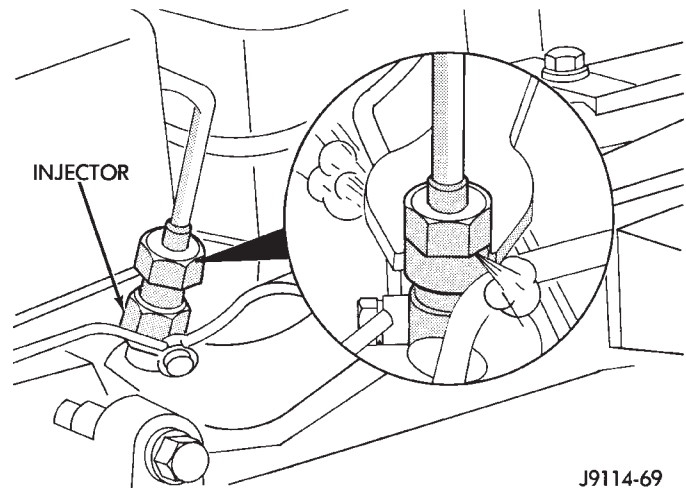

Fig. 19 Bleeding High-Pressure Fuel Line—Typical FUEL INJECTION PUMP TIMING

Refer to the Fuel Injection Pump Removal and Installation procedure in Service Procedures later in this Group.

REMOVAL AND INSTALLATION

AIR CLEANER ELEMENT

REMOVAL

- (1) Loosen 4 clamps holding air cleaner housing halves together.
- (2) Remove top of air cleaner housing.
- (3) Remove element from air cleaner housing.

INSTALLATION

- (1) Install a new element in housing.
- (2) Position housing halves together.
- (3) Snap clamps into place.

FUEL DRAIN TUBES

The fuel drain tubes (Fig. 20) are low-pressure type.

Pull each tube from the injector for removal. Push on for installation. Clamps are not required for these tubes.

FUEL FILTER/WATER SEPARATOR

The fuel filter/water separator is located in the engine compartment on the left side behind the generator (Fig. 21).

The fuel filter/water separator assembly contains the fuel filter, fuel heater element, and fuel drain valve.

DRAINING WATER FROM FILTER BOWL

Moisture (water) collects at the bottom of the filter/separator in a plastic bowl. Water entering the fuel

REMOVAL AND INSTALLATION (Continued)

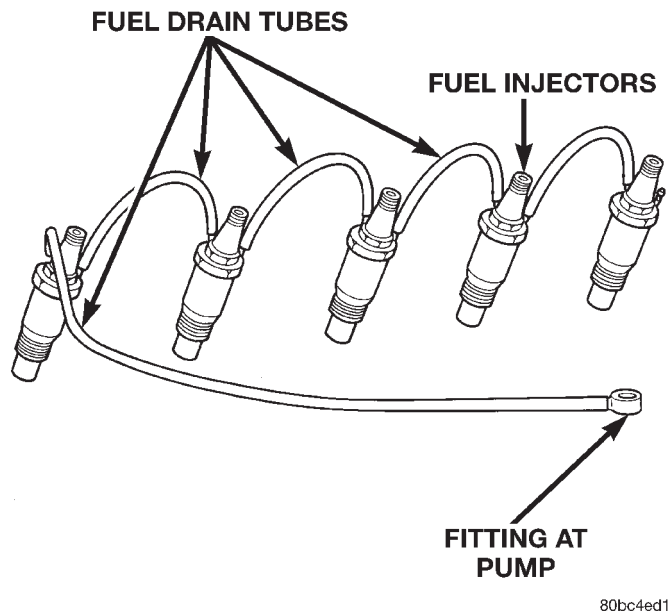

Fig. 20 Fuel Injectors and Drain Tubes

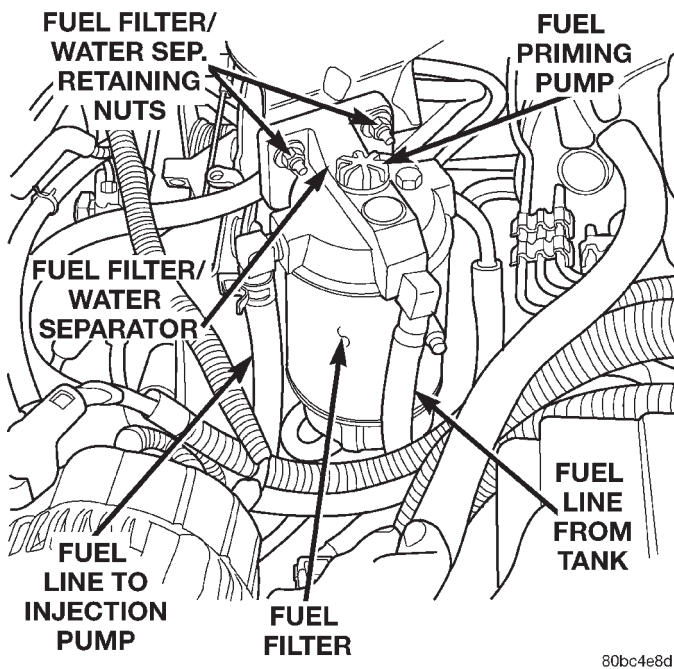

Fig. 21 Fuel Filter / Water Separator Position & Orientation

injection pump can cause serious damage to the pump. Note that the bulb will be illuminated for approximately 2 seconds each time the key is initially placed in the ON position. This is done for a bulb check.

WARNING: DO NOT ATTEMPT TO DRAIN WATER FROM THE FILTER/SEPARATOR WITH THE ENGINE HOT.

(1) The bottom of the filter/separator bowl is equipped with a drain valve. The drain valve is equipped with a fitting. Attach a piece of rubber hose to this fitting. This hose is to be used as a drain hose.

(2) Place a drain pan under the drain hose.

(3) With the engine not running, open the drain valve (unscrew—drain valve has right hand threads) from the filter/separator bowl. To gain access to this fitting, the two filter-to-mounting bracket nuts may have to be loosened a few turns.

(4) Hold the drain open until clean fuel exits the drain.

(5) After draining, close drain valve.

(6) Remove rubber drain hose.

(7) Dispose of mixture in drain pan according to applicable local or federal regulations.

FUEL FILTER REMOVAL

(1) Drain all fuel and/or water from fuel filter/water separator assembly. Refer to the previous Draining Water From Filter Bowl.

(2) Unplug the electrical connectors at bottom of plastic bowl.

(3) Remove plastic bowl from bottom of fuel filter (unscrews).

(4) Remove fuel filter from bottom of filter base (unscrews).

FUEL FILTER INSTALLATION

(1) Clean bottom of fuel filter base.

(2) Apply clean diesel fuel to new fuel filter gasket.

(3) Install and tighten filter to filter base. The beveled part of the rubber gasket should be facing up towards the filter base.

(4) Clean the inside of bowl with a soap and water mixture before installation. Carefully clean any residue between the two metal probes at the top of the water-in-fuel sensor. Do not use chemical cleaners as damage to the plastic bowl may result.

(5) Pour diesel fuel into the plastic bowl before installing bowl to bottom of fuel filter. Do this to help prevent air from entering fuel injection pump while attempting to starting engine.

(6) Install filter bowl to bottom of filter.

(7) Install the electrical connectors at bottom of bowl.

(8) Tighten the filter-to-mounting bracket nuts (Fig. 21) to 28 N·m (250 in. lbs.) torque.

FUEL HEATER

If the fuel heater element needs replacement, the plastic filter bowl assembly must be replaced. Refer to Fuel Filter/Water Separator for information.

REMOVAL AND INSTALLATION (Continued)

FUEL HEATER RELAY

The fuel heater relay is located in the PDC. For the location of the relay within the PDC (Fig. 22), refer to label on PDC cover.

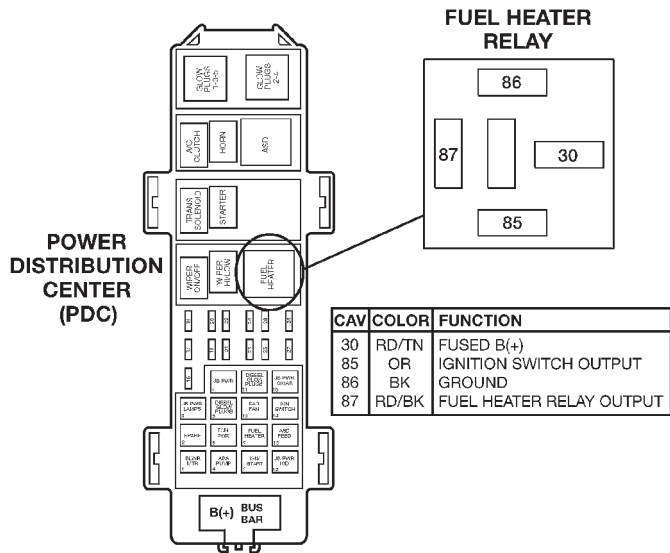

Fig. 22 Power Distribution Center (PDC)

FUEL LEVEL SENSOR

The fuel level sensor is located on the side of the fuel pump module.

REMOVAL

- (1) Remove fuel tank. Refer to Fuel Tank Removal/Installation.
- (2) Remove fuel pump module. Refer to Fuel Pump Module Removal/Installation
- (3) Remove electrical wire connector at sending unit terminals.
- (4) Press on release tab (Fig. 23) to remove level sensor from the pump module.

FUEL INJECTION PUMP

REMOVAL

- (1) Disconnect the negative battery cable.
- (2) Remove the intake air duct retaining bolts from the top of the intake manifold.
- (3) Disconnect the intercooler outlet hose from the intercooler.
- (4) Remove the engine intake air duct and hose assembly from the vehicle.
- (5) Remove the engine accessory drive belt. Refer to Group 7, Cooling System for the procedure.
- (6) Remove the generator assembly. Refer to Group 8C, Charging System for the procedure.
- (7) Thoroughly clean the area around the injection pump and fuel lines of all dirt, grease and other contaminants. **Due to the close internal tol-**

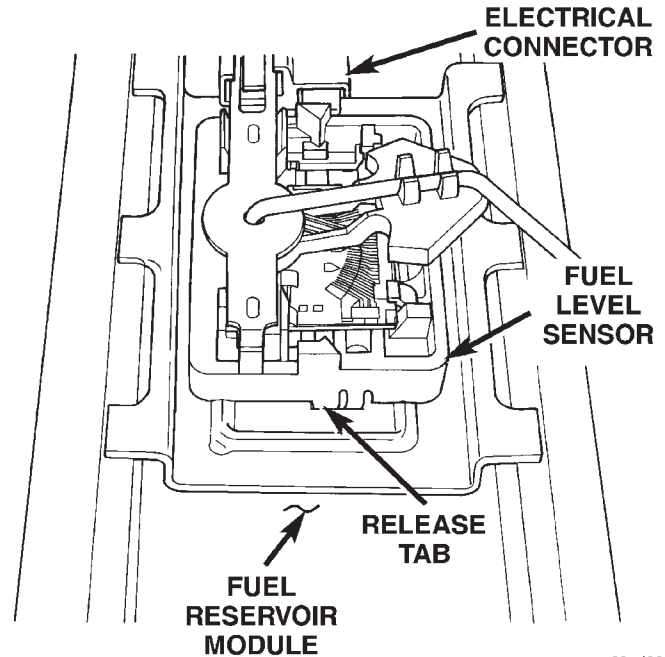

80ad090e

Fig. 23 Fuel Level Sensor Release Tab

erances of the injection pump, this step must be performed before removing pump.

- (8) Remove the rubber fuel return and supply hoses from the metal lines at the pump (Fig. 24).

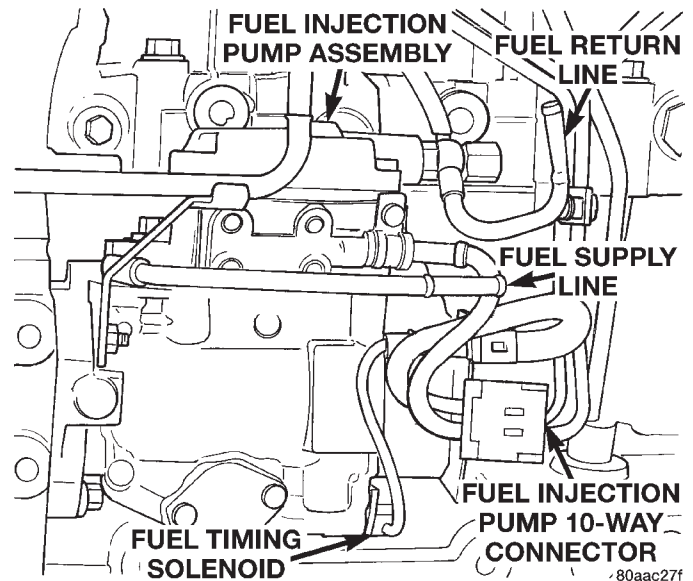

80aac27f

Fig. 24 Fuel Injection Pump

- (9) Disconnect the engine coolant temperature sensor electrical connector (Fig. 25). Located closest to the injection pump.

- (10) Disconnect the Fuel Injection Pump electrical connector at the pump. (Fig. 24).

- (11) Disconnect the main engine wiring harness from the glow plugs.

REMOVAL AND INSTALLATION (Continued)

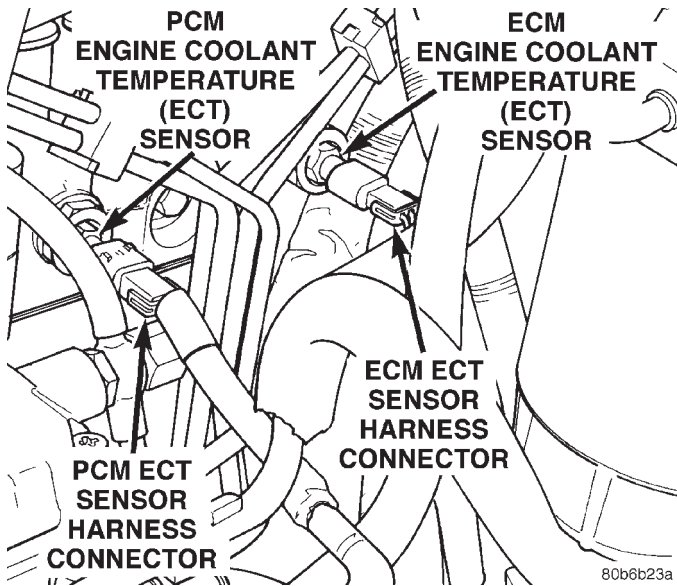

Fig. 25 Engine Coolant Temperature Sensors

(12) Disconnect the five high-pressure fuel lines from the fuel injection pump. Also disconnect fuel lines at the fuel injectors. For procedures, refer to High-Pressure Fuel Lines in this group. Place a rag beneath the fittings to catch excess fuel.

(13) Remove the plug from timing gear cover.

(14) The "Top Dead Center" (T.D.C.) compression firing position for the #1 cylinder can be determined as follows:

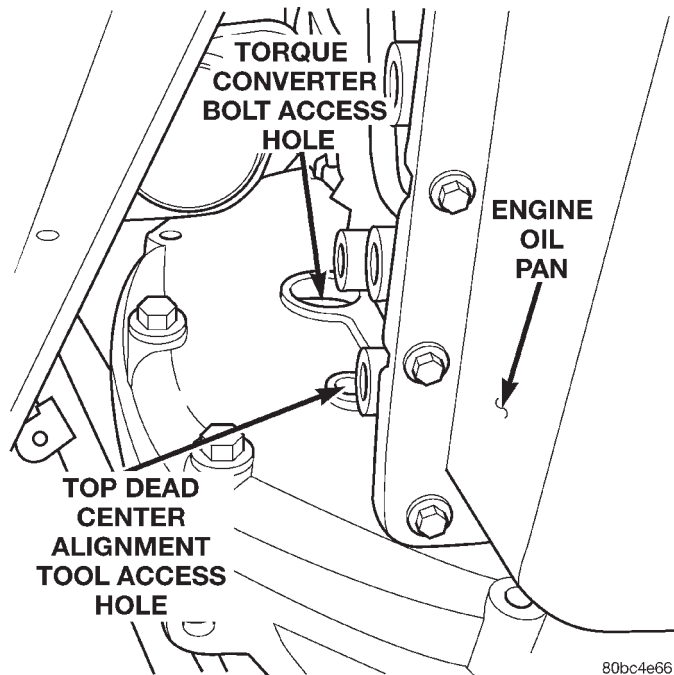

Fig. 26 Top Dead Center Alignment Tool Access Hole

(a) Using a socket attached to the front of the crankshaft, rotate the engine clockwise until spe-

cial alignment tool VM# 8374 can be inserted through the T.D.C. tool access hole in the right side of the transmission adapter plate (Fig. 26), stopping the flywheel rotation. This position is T.D.C. or 360° (crankshaft deg.) away from T.D.C. **Engine must be positioned at T.D.C. on #1 cylinder compression firing stroke.**

(b) To verify that you are at T.D.C. Remove the oil fill cap from the cylinder head cover and the alignment tool from the transmission adapter plate.

(c) Rotate the crankshaft one-quarter turn counter-clockwise and clockwise while observing the cylinder #2 intake rocker arm through the oil fill cap hole. (The intake valve rocker arm should stop moving). If the rocker arm does not move you have identified T.D.C.

(d) If T.D.C. was found continue the procedure, if not rotate the crankshaft one revolution (360°) until the alignment tool can be re-installed in the flexplate (Fig. 26). T.D.C. is now identified for the #1 cylinder compression firing stroke. Mark the damper and timing cover for quick reference to T.D.C. Remove the alignment tool from the transmission adapter plate.

(15) Remove access plug and plug washer at rear of pump (Fig. 27). Thread special dial indicator and adapter tool VM# 1011 (Fig. 28) into this opening. Hand tighten only.

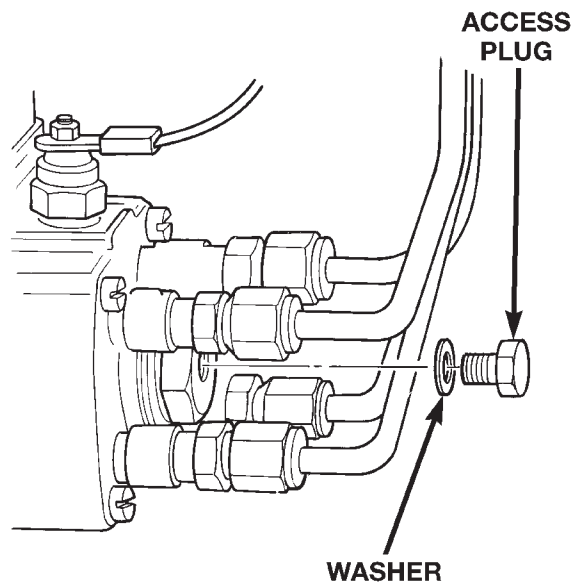

Fig. 27 Access Plug at Rear of Pump

(16) Slowly rotate the engine in a counter-clockwise direction until the dial gauge indicator stops moving (20°-25° before T.D.C.).

REMOVAL AND INSTALLATION (Continued)

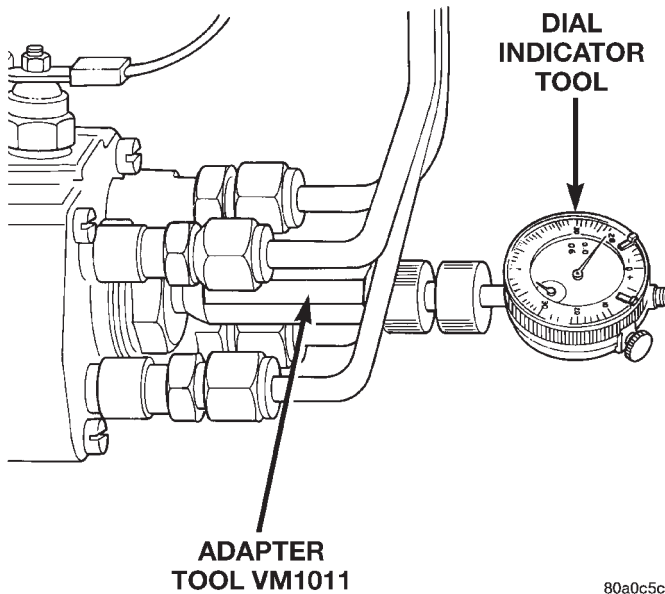

Fig. 28 Installing Dial Indicator and Special Adapter Tools

(17) Remove the injection pump drive gear nut (Fig. 29).

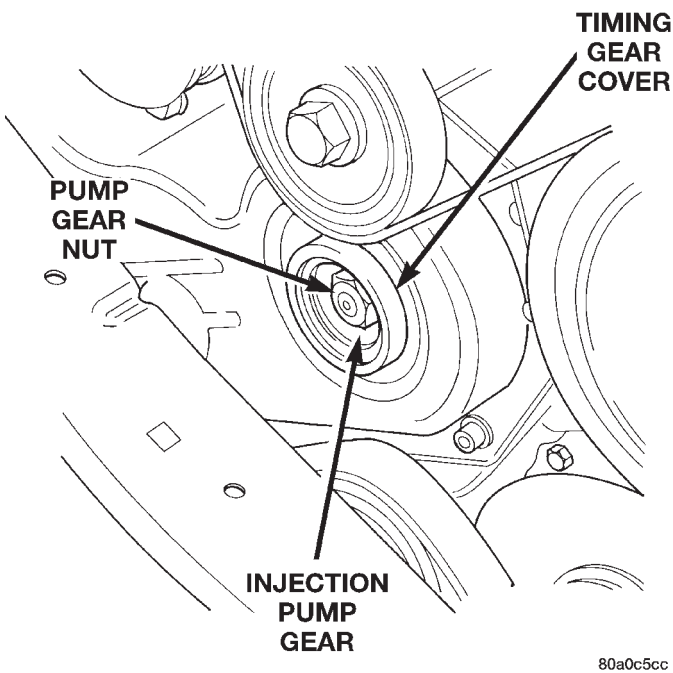

Fig. 29 Removing Pump Drive Gear Nut

(18) A special 3-piece gear removal tool set VM# 1003 (Fig. 30) must be used to remove the injection pump drive gear from the pump shaft.

(a) Thread the adapter (Fig. 31) into the timing cover.

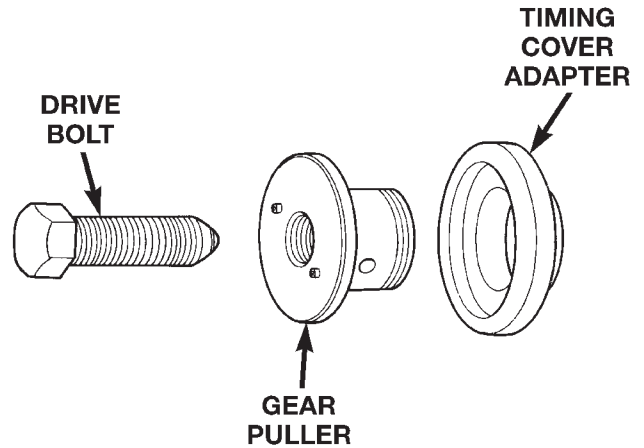

Fig. 30 Pump Gear Tools

(b) Thread the gear puller into the injection pump drive gear (Fig. 31). This tool is also used to hold the gear in synchronization during pump removal.

(c) Remove the three injection pump-to-gear cover mounting nuts (Fig. 32). **CAUTION: This step must be done to prevent injection pump damage.**

(d) Install the drive bolt into the gear puller (Fig. 31). Tighten the drive bolt to press (remove) the drive gear from injection pump shaft while driving injection pump rearward from timing gear cover mounting studs.

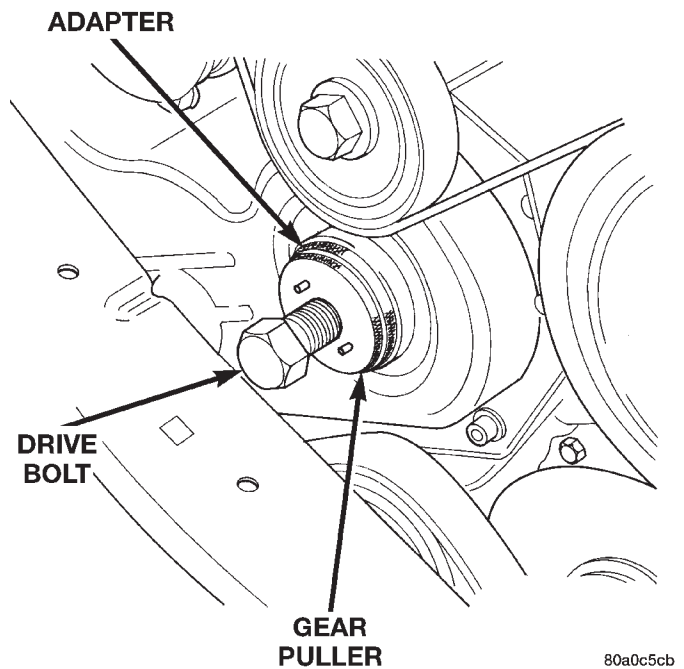

Fig. 31 Installing Pump Drive Gear Removal Tools

REMOVAL AND INSTALLATION (Continued)

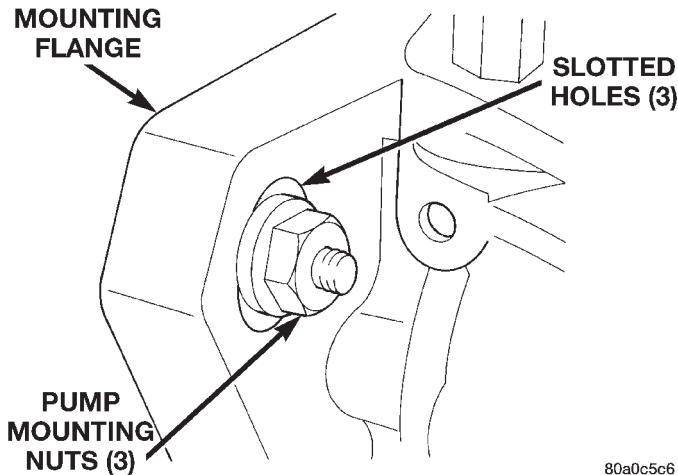

Fig. 32 Injection Pump Mounting Nuts

(19) Remove pump from engine. **Do not rotate engine while gear puller is installed. Engine damage will occur.**

INSTALLATION / ADJUSTING INJECTION PUMP TIMING

NOTE: Engine should be positioned at 20°- 25° degrees before T.D.C.

- (1) Clean the mating surfaces of injection pump and timing gear cover.
- (2) Install a new injection pump-to-timing gear cover gasket.
- (3) Remove the gear removing bolt (drive bolt) from gear puller. **CAUTION: Do not remove the special gear puller or timing cover adapter tools from timing cover at this time. Gear misalignment will result.**
- (4) Place the key way on the pump shaft to the 11 o'clock position as viewed from the front of pump. Install the pump into the rear of timing gear cover while aligning the key way on pump shaft into pump gear.
- (5) Install and snug the 3 injection pump mounting nuts. This is not the final tightening sequence.
- (6) Remove the special gear puller and adapter tools from timing gear cover.
- (7) Install the injection pump drive gear nut. Torque the nut to 88 N·m (65 ft. lbs.) torque.
- (8) Remove the access plug and plug washer at rear of pump (Fig. 33). Thread special dial indicator adapter tool VM# 1011 (Fig. 34) into this opening. Hand tighten only.
- (9) Attach special dial indicator tool VM# 1013 into the adapter tool (Fig. 34)
- (10) Using a socket attached to the front of the crankshaft, rotate the engine in a counter-clockwise direction until

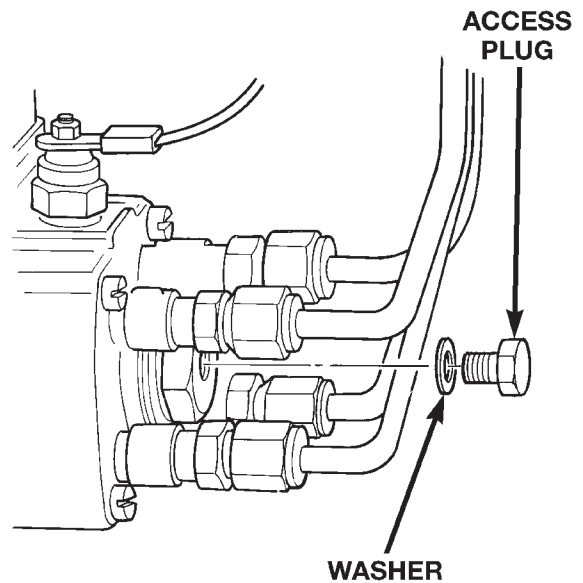

Fig. 33 Access Plug at Rear of Pump

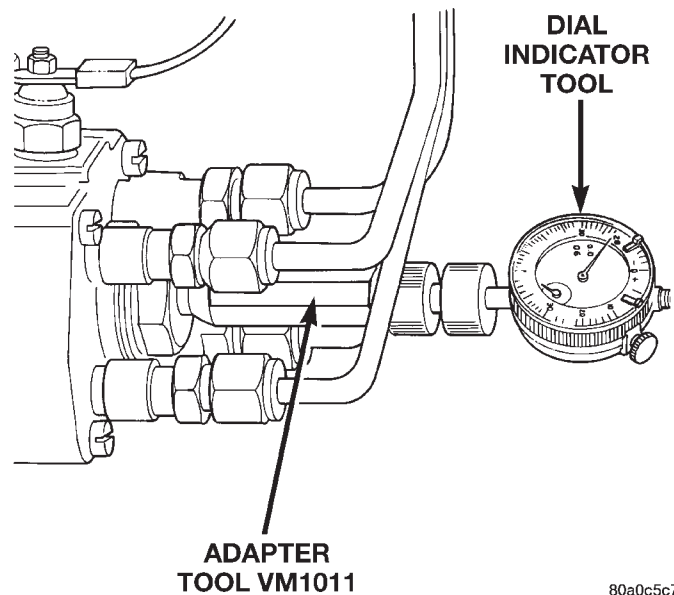

Fig. 34 Installing Dial Indicator and Special Adapter Tools

the dial gauge indicator stops moving (20°-25° before T.D.C.).

(11) Set the dial indicator to 0 mm. Be sure the tip of the dial indicator is touching the tip inside the adapter tool.

(12) Rotate the crankshaft clockwise until the alignment tool can be reinstalled in the flexplate (Fig. 35).

REMOVAL AND INSTALLATION (Continued)

NOTE: Engine must be positioned at T.D.C. #1 cylinder compression stroke.

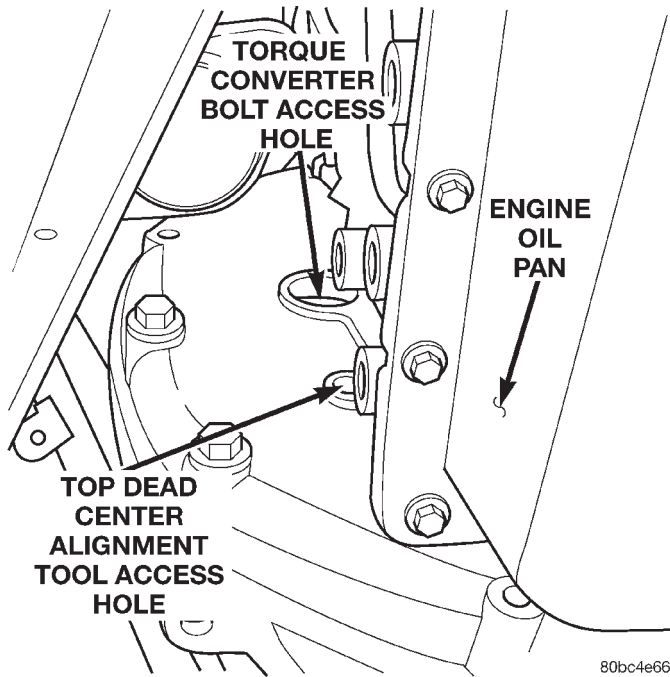

Fig. 35 Top Dead Center Alignment Tool Access Hole

(13) The gauge reading should be at 0.45 mm. If not, the pump must be rotated for adjustment:

NOTE: If the engine is fitted with all new gears, the specification is 0.49 - 0.50 mm.

(a) Loosen the three injection pump mounting nuts at the mounting flanges. These flanges are equipped with slotted holes. The slotted holes are used to rotate and position the injection pump for fuel timing. Loosen the three nuts just enough to rotate the pump.

(b) Rotate the pump until 0.45 mm is indicated on the dial indicator gauge. If while rotating the pump the 0.45 mm specification is passed do not attempt to rotate the pump in the opposite direction. You must rotate the pump back to 0.15 mm and start the procedure over from the start of the T.D.C. procedure. This will prevent a false reading due to gear backlash.

(c) Tighten the three pump mounting nuts to 30 N·m (22 ft. lbs.) torque.

(d) Recheck the dial indicator after tightening the pump mounting nuts. Gauge should still be reading 0.45 mm at T.D.C.

(14) Remove the dial indicator and adapter tools.

(15) Install access plug and washer to rear of injection pump.

(16) Install plug at timing gear cover.

(17) Install and connect the five high-pressure fuel lines to the fuel injection pump. Also connect fuel lines at the fuel injectors. For procedures, refer to High-Pressure Fuel Lines in this group.

(18) Install electrical connector at engine coolant temperature sensor.

(19) Connect electrical connector at fuel shutdown solenoid.

(20) Connect the main engine wiring harness to the glow plugs.

(21) Connect the fuel timing solenoid pigtail harness to the engine wiring harness.

(22) Connect the overflow valve/banjo fitting (fuel return line assembly). Replace copper gaskets before installing.

(23) Connect the rubber fuel return and supply hoses to metal lines at pump. Tighten hose clamps to 2 N·m (20 in. lbs.) torque.

(24) Install the generator assembly. Refer to Group 8C, Charging System for the procedure.

(25) Install the engine accessory drive belt. Refer to Group 7, Cooling System for the procedure.

(26) Position the gasket and install the intake air duct on the intake manifold. Torque the bolts to 27 N·m (20 ft. lbs.).

(27) Install the intercooler outlet hose on the intercooler.

(28) Connect the negative battery cable.

(29) Start the engine and bring to normal operating temperature.

(30) Check for fuel leaks.

FUEL INJECTORS

Four fuel injectors are used on each engine. Of these four, two different types are used. The fuel injector used on cylinder number one is equipped with a fuel injector sensor (Fig. 36). The other three fuel injectors are identical. **Do not place the fuel injector equipped with the fuel injector sensor into any other location except the cylinder number one position.**

REMOVAL

(1) Disconnect negative battery cable at battery.

(2) Thoroughly clean the area around the injector with compressed air.

(3) Remove the fuel drain hoses (tubes) at each injector (Fig. 37) being serviced. Each of these hoses is slip-fit to the fitting on injector.

(4) Remove the high-pressure fuel line at injector being removed. Refer to High-Pressure Fuel Lines in this group for procedures.

(5) Remove the injector using special socket tool number VM.1012A. When removing cylinder number one injector, thread the wiring harness through the access hole on the special socket (Fig. 38).

REMOVAL AND INSTALLATION (Continued)

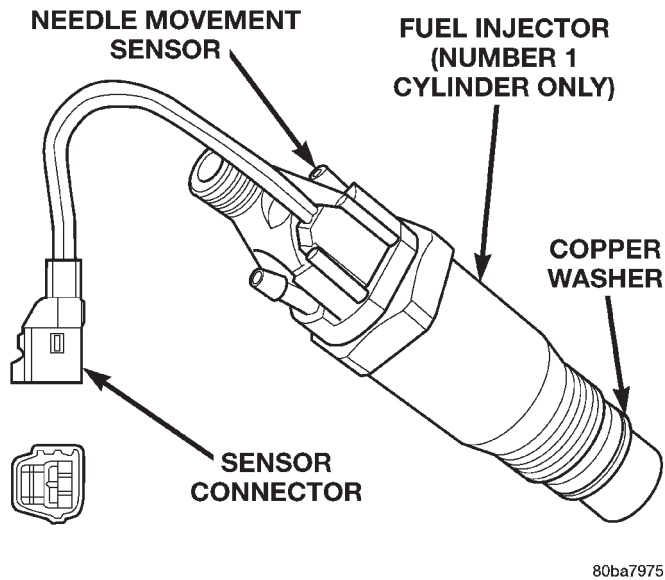

80ba7975

Fig. 36 Fuel Injector Sensor — #1 Cylinder

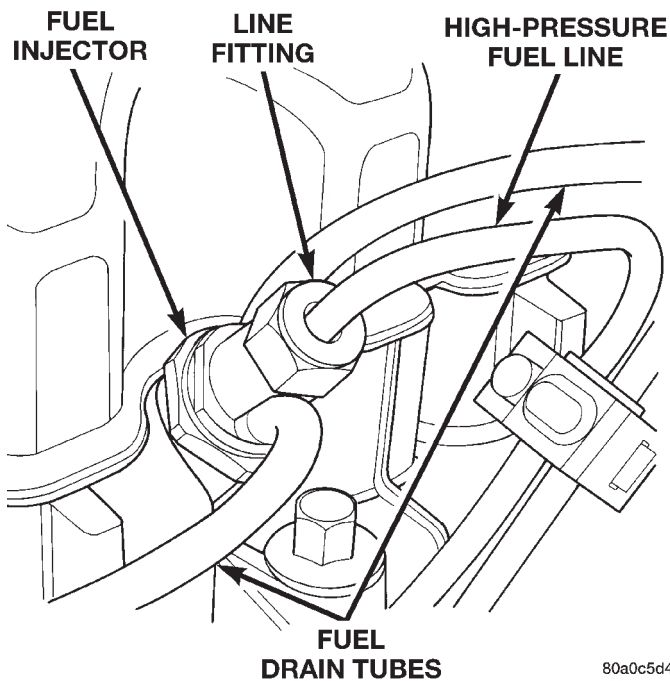

80a0c5d4

Fig. 37 Fuel Injector—Typical

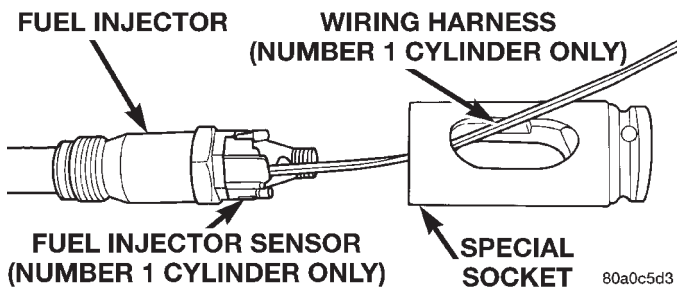

80a0c5d3

Fig. 38 Wiring Harness Through Socket

(6) Remove and discard the copper washer (seal) at bottom of injector (Fig. 36).

INSTALLATION

- (1) Clean the injector threads in cylinder head.
- (2) Install new copper washer (seal) to injector.
- (3) Install injector to engine. Tighten to 70 N·m (52 ft. lbs.) torque.
- (4) Install high-pressure fuel lines. Refer to High-Pressure Fuel Lines in this group for procedures.
- (5) Install fuel drain hoses (tubes) to each injector. Do not use clamps at fuel drain hoses.
- (6) Connect negative battery cable to battery.
- (7) Bleed the air from the high-pressure lines. Refer to the Air Bleed Procedure section of this group.

HIGH-PRESSURE LINES

All high-pressure fuel lines are of the same length and inside diameter. Correct high-pressure fuel line usage and installation is critical to smooth engine operation.

CAUTION: The high-pressure fuel lines must be clamped securely in place in the holders. The lines cannot contact each other or other components. Do not attempt to weld high-pressure fuel lines or to repair lines that are damaged. Only use the recommended lines when replacement of high-pressure fuel line is necessary.

REMOVAL

- (1) Disconnect negative battery cable from battery.
- (2) Remove the necessary clamps holding the lines to the engine.
- (3) Clean the area around each fuel line connection. Disconnect each line at the top of each fuel injector (Fig. 39).
- (4) Disconnect each high-pressure line fitting at each fuel injection pump delivery valve.
- (5) Very carefully remove each line from the engine. Note the position (firing order) of each line while removing. **Do not bend the line while removing.**

CAUTION: Be sure that the high-pressure fuel lines are installed in the same order that they were removed. Prevent the injection pump delivery valve holders from turning when removing or installing high-pressure lines from injection pump.

REMOVAL AND INSTALLATION (Continued)

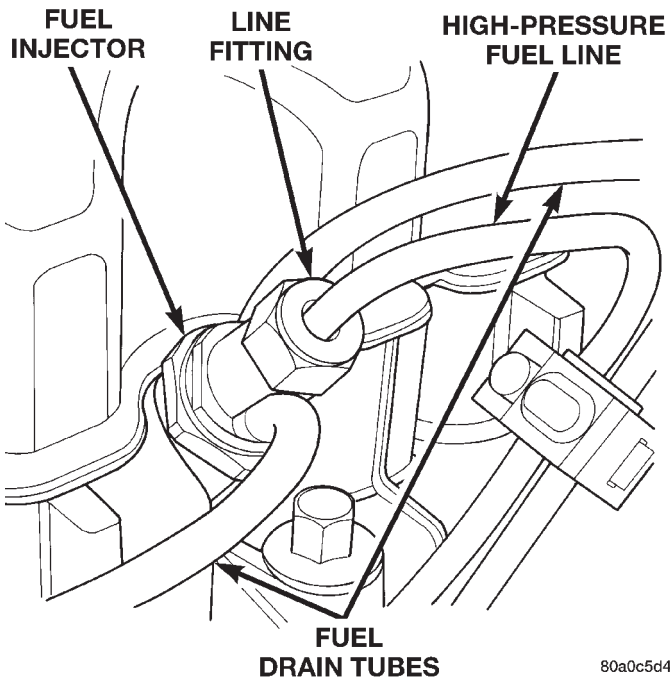

80a0c5d4

Fig. 39 Fuel Lines at Fuel Injectors

INSTALLATION

- (1) Carefully position each high-pressure fuel line to the fuel injector and fuel injection pump delivery valve holder in the correct firing order. Also position each line in the correct line holder.
- (2) Loosely install the line clamp/holder bolts.
- (3) Tighten each line at the delivery valve to 19 N·m (168 in. lbs.) torque.

- (4) Tighten each line at the fuel injector to 19 N·m (168 in. lbs.) torque.

Be sure the lines are not contacting each other or any other component.

- (5) Bleed air from the fuel system. Refer to the Air Bleed Procedure section of this group.

SPECIFICATIONS

FUEL TANK CAPACITY

78 Liters (20.5 Gals.)

Nominal refill capacities are shown. A variation may be observed from vehicle to vehicle due to manufacturing tolerances, ambient temperatures and refill procedures.

IDLE SPEED

750 RPM \pm 25 RPM with engine at normal operating temperature.

FUEL INJECTOR FIRING SEQUENCE

1-2-4-5-3

FUEL SYSTEM PRESSURE

Peak Injection Pressure/Fuel Injection Pump Operating Pressure: 40,000–45,000 kPa (5801–6526 psi).

Opening Pressure of Fuel Injector: 16,500–17,300 kPa (2393–2509 psi).

FUEL INJECTION SYSTEM—3.1L DIESEL ENGINE

INDEX

	page		page
GENERAL INFORMATION			
INTRODUCTION	21	POWERTRAIN CONTROL MODULE (PCM) AND ENGINE CONTROL MODULE (ECM).	22
DESCRIPTION AND OPERATION			
AIR CONDITIONING (A/C) CONTROLS— ECM INPUTS	24	SENSOR RETURN—ECM/PCM INPUT (ANALOG GROUND).	23
AIR CONDITIONING RELAY—ECM OUTPUT	25	SPEED CONTROL—ECM INPUT	25
ASD RELAY—ECM INPUT	25	SPEED CONTROL—PCM OUTPUTS	25
BATTERY VOLTAGE—PCM INPUT	23	TACHOMETER—PCM OUTPUT	26
BOOST / PRESSURE SENSOR	22	TIMING SOLENOID—ECM OUTPUT	25
BRAKE SWITCH—ECM INPUT	24	VEHICLE THEFT ALARM	23
DATA LINK CONNECTOR—PCM AND ECM INPUT AND OUTPUT	25	DIAGNOSIS AND TESTING	
ELECTRIC VACUUM MODULATOR (EVM)— ECM OUTPUT	27	ASD RELAY TEST	27
ENGINE COOLANT GAUGE—PCM OUTPUT	25	BOOST / PRESSURE SENSOR	30
ENGINE COOLANT TEMPERATURE SENSOR—ECM/PCM INPUT	24	DIAGNOSTIC TROUBLE CODES	31
ENGINE OIL PRESSURE GAUGE—PCM OUTPUT	25	DIESEL DIAGNOSTICS	27
ENGINE SPEED/CRANK POSITION SENSOR—ECM INPUT	24	ENGINE COOLANT TEMPERATURE SENSOR TEST	27
FIVE VOLT POWER—ECM/PCM OUTPUT	25	ENGINE SPEED SENSOR TEST	27
FUEL INJECTOR SENSOR—GROUND	24	GLOW PLUG RELAY TEST	29
GLOW PLUG LAMP—PCM OUTPUT	25	GLOW PLUG TEST	28
GLOW PLUG RELAY—ECM OUTPUT	26	RELAYS—OPERATION/TESTING	29
GLOW PLUGS	27	VEHICLE SPEED SENSOR TEST	31
IGNITION CIRCUIT SENSE—PCM/ECM INPUT	23	REMOVAL AND INSTALLATION	
NEEDLE MOVEMENT OR INSTRUMENTED FIRST INJECTOR—ECM INPUT	23	A/C CLUTCH RELAY	31
POWER GROUND	23	ASD RELAY	31
		ENGINE COOLANT TEMPERATURE SENSOR	33
		ENGINE SPEED SENSOR	31
		GLOW PLUGS	34
		SPECIFICATIONS	
		GLOW PLUG CURRENT DRAW	35
		TORQUE CHART—3.1L DIESEL	35

GENERAL INFORMATION

INTRODUCTION

This section will cover components either regulated or controlled by the ECM controller and the Powertrain Control Module (PCM). The fuel heater relay and fuel heater are not operated by the ECM controller or the PCM. These components are controlled by the ignition (key) switch. All other fuel system electrical components necessary to operate the engine are controlled or regulated by the ECM controller, which interfaces with the PCM. Refer to the following description for more information.

Certain fuel system component failures may cause a no start, or prevent the engine from running. It is important to know that the ECM has a feature where, if possible, it will ignore the failed sensor, set

a code related to the sensor, and operate the engine in a "Limp Home" mode. When the ECM is operating in a "Limp Home" mode, the Check Engine Lamp on the instrument panel may be constantly illuminated, and the engine will most likely have a noticeable loss of performance. An example of this would be an Accelerator Pedal Position Sensor failure, and in that situation, the engine would run at a constant 1100 RPM, regardless of the actual position of the pedal. This is the most extreme of the three "Limp Home" modes.

When the Check Engine Lamp is illuminated constantly with the key on and the engine running,, it usually indicates a problem has been detected somewhere within the fuel system. The DRBIII scan tool is the best method for communicating with the ECM and PCM to diagnose faults within the system.

DESCRIPTION AND OPERATION

POWERTRAIN CONTROL MODULE (PCM) AND ENGINE CONTROL MODULE (ECM)

The Engine Control Module (ECM) is mounted underneath the left rear seat. The Powertrain Control Module (PCM) is mounted in the engine compartment.

The ECM Controller is a pre-programmed, digital computer. It will either directly operate or partially regulate the:

- Speed Control
- Speed Control lamp
- Fuel Timing Solenoid
- Check Engine Light
- Glow Plug Relay
- Glow Plugs
- Glow Plug Lamp
- ASD Relay
- Air Conditioning
- Tachometer
- Electric Vacuum Modulator (EVM)

The ECM can adapt its programming to meet changing operating conditions.

The ECM receives input signals from various switches and sensors. Based on these inputs, the ECM regulates various engine and vehicle operations through different system components. These components are referred to as **ECM Outputs**. The sensors and switches that provide inputs to the ECM are considered **ECM Inputs**.

ECM Inputs are:

- Air Conditioning Selection
- Theft Alarm
- ASD Relay
- Control Sleeve Position Sensor
- Fuel Temperature Sensor
- Mass Air Flow Sensor
- Accelerator Pedal Position Sensor
- Engine Coolant Temperature Sensor
- Low Idle Position Switch
- 5 Volt Supply
- Vehicle Speed Sensor
- Engine Speed/Crank Position Sensor (rpm)
- Needle Movement Sensor
- Starter Signal
- Brake Switch
- Speed Control Switch
- Power Ground
- Ignition (key) Switch Sense

ECM Outputs:

After inputs are received by the ECM and PCM, certain sensors, switches and components are controlled or regulated by the ECM and PCM. These are considered **ECM Outputs**. These outputs are for:

- A/C Clutch Relay (for A/C clutch operation)
- Speed Control Lamp
- ASD Relay
- 5 Volts Supply
- Fuel Quantity Actuator
- Fuel Timing Solenoid
- Fuel Shutdown Solenoid
- Glow Plug Lamp
- Check Engine Lamp (“On/Off” signal)
- Electric Vacuum Modulator (EVM)
- Glow Plug Relay
- Tachometer

The PCM sends and receives signals to and from the ECM controller. **PCM inputs are:**

- Power Ground
- 5 Volts Supply
- Vehicle Speed Sensor
- Water-In-Fuel Sensor
- Coolant Temperature Sensor
- Low Coolant Sensor
- Sensor Return
- Fuel Level Sensor
- Oil Pressure Sensor
- Tachometer Signal
- Glow Plug Lamp
- Check Engine Lamp (“On/Off” signal)
- Brake On/Off Switch
- Battery Voltage
- ASD Relay

PCM Outputs:

- A/C On Signal
- Vehicle Theft Alarm “Ok to Run” signal
- Body Control Module CCD Bus (+)
- Body Control Module CCD Bus (-)
- Scan Tool Data Link Receive
- Scan Tool Data Link Transmit
- Low Coolant Lamp
- Generator Control

BOOST / PRESSURE SENSOR

The Boost Pressure Sensor is mounted to the top of the intake manifold (Fig. 1). It is a sensor that measures both manifold vacuum and turbo boost, and it also contains an integrated intake air temperature sensor. The Boost Pressure Sensor takes the place of the Mass Air Flow (MAF). In the Intake Air Temperature Sensor component, there is a ceramic element that changes its resistance based on temperature. The ceramic element is part of an electronic circuit connected to the PCM, and has a voltage applied to it. The ceramic element is exposed to the air inside the intake. This air has a cooling effect on the ceramic element, and its resistance changes. This causes the voltage flowing through the intake air temperature circuit to vary. The voltage signal produced by the Intake Air Temperature Sensor changes

DESCRIPTION AND OPERATION (Continued)

inversely to the temperature, and is measured by the PCM. As a general rule, when the temperature of the air in the intake is high, the voltage signal produced by the Intake Air Temperature Sensor is low. The component of the Boost Pressure Sensor that measures manifold vacuum and turbo boost produces a voltage signal that is proportional to the pressure in the intake manifold. When the intake manifold pressure is low, the voltage is low, and when the pressure is high, the voltage is high. The PCM uses the voltage signals from the Boost Pressure Sensor, and the Intake Air Temperature Sensor to determine the amount of air flowing through the intake manifold.

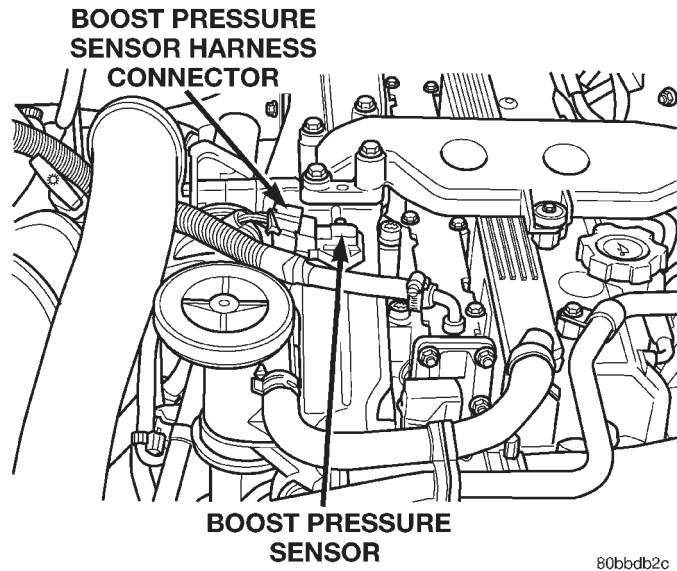

Fig. 1 Boost Pressure Sensor Location

VEHICLE THEFT ALARM

The PCM can learn if the vehicle has a Vehicle Theft Alarm (VTA) system. Once it detects the vehicle having VTA, **the controller can ONLY BE USED ON VEHICLES WITH VTA.**

If the PCM is put it on a vehicle without VTA the Glow Plug Lamp will start to blink and the vehicle will not start.

The PCM cannot be flashed to remove the VTA.

BATTERY VOLTAGE—PCM INPUT

The battery voltage input provides power to the PCM. It also informs the PCM what voltage level is being supplied by the generator once the vehicle is running.

The battery input also provides the voltage that is needed to keep the PCM memory alive. The memory stores Diagnostic Trouble Code (DTC) messages. Trouble codes will still be stored even if the battery voltage is lost.

SENSOR RETURN—ECM/PCM INPUT (ANALOG GROUND)

Sensor Return provides a low noise Analog ground reference for all system sensors.

IGNITION CIRCUIT SENSE—PCM/ECM INPUT

The ignition circuit sense input signals the PCM and ECM that the ignition (key) switch has been turned to the ON position. This signal initiates the glow plug control routine to begin the “pre-heat” cycle.

POWER GROUND

Provides a common ground for power devices (solenoid and relay devices).

NEEDLE MOVEMENT OR INSTRUMENTED FIRST INJECTOR—ECM INPUT

This input from the ECM supplies a constant 30 mA electrical current source for the first injector sensor. It will vary the voltage to this sensor when it senses a mechanical movement within the injector needle (pintle) of the number-1 cylinder fuel injector. When this voltage has been determined by the ECM, it will then control an output to the fuel timing solenoid (the fuel timing solenoid is located on the fuel injection pump). Also refer to Fuel Injection Pump for additional information.

The first injector sensor is a magnetic (inductive) type.

The first injector sensor is used only on the fuel injector for the number-1 cylinder (Fig. 2).

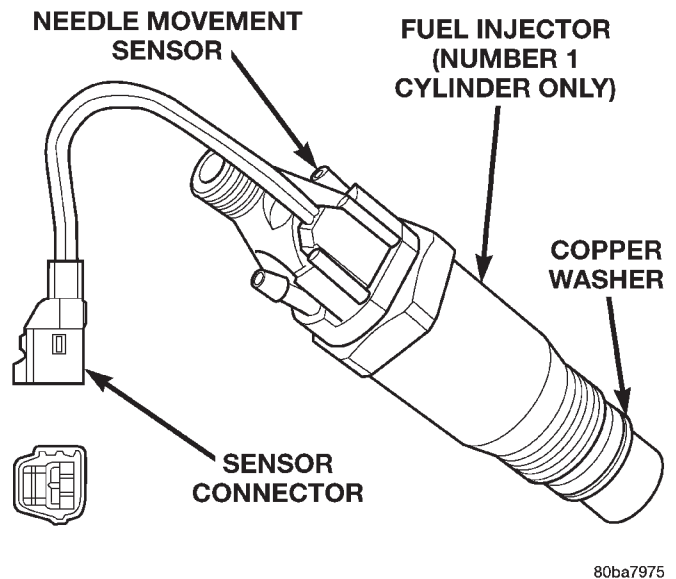

Fig. 2 Fuel Injector Sensor

DESCRIPTION AND OPERATION (Continued)

FUEL INJECTOR SENSOR—GROUND

Provides a low noise ground for the fuel injector sensor only.

ENGINE COOLANT TEMPERATURE SENSOR—ECM/PCM INPUT

The 0–5 volt input from this sensor tells the ECM and PCM the temperature of the engine coolant. Based on the voltage received at the ECM, it will then determine operation of the fuel timing solenoid, glow plug relay, electrical vacuum modulator (emission component) and generator (charging system).

The sensor is located on the side of the #3 cylinder head near the rear of fuel injection pump (Fig. 3).

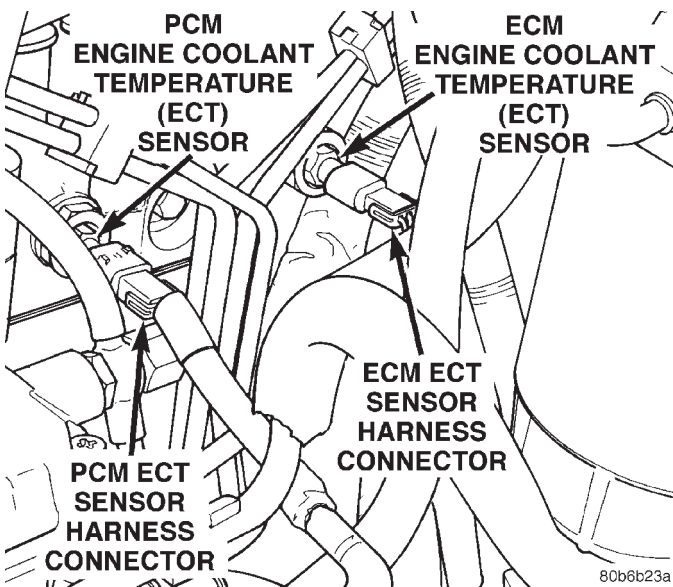

Fig. 3 Engine Coolant Temperature Sensor Location

ENGINE SPEED/CRANK POSITION SENSOR—ECM INPUT

The engine speed sensor is mounted to the transmission bellhousing at the right/rear side of the engine block (Fig. 4).

The engine speed sensor produces its own output signal. If this signal is not received, the ECM will not allow the engine to start.

The engine speed sensor input is used in conjunction with the first injector sensor to establish fuel injection pump timing.

The flywheel has five notches at its outer edge. Each notch is spaced equally every 72°. The notches cause a pulse to be generated when they pass under the speed sensor. These pulses are the input to the ECM. The input from this sensor determines crankshaft position (in degrees) by monitoring the notches.

The sensor also generates an rpm signal to the ECM. This signal is used as an input for the control of the generator field, vehicle speed control, and instrument panel mounted tachometer.

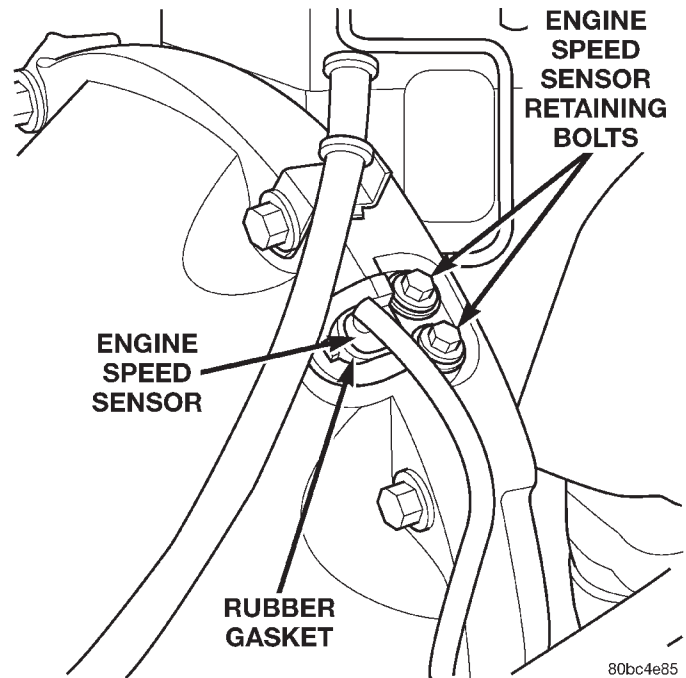

Fig. 4 Engine Speed Sensor Location

If the engine speed sensor should fail, the system is unable to compensate for the problem and the car will stop.

AIR CONDITIONING (A/C) CONTROLS—ECM INPUTS

The A/C control system information applies to factory installed air conditioning units.

A/C REQUEST SIGNAL: When either the A/C or Defrost mode has been selected and the A/C low and high-pressure switches are closed, an input signal is sent to the ECM. The ECM uses this input to cycle the A/C compressor through the A/C relay.

If the A/C low or high-pressure switch opens, the ECM will not receive an A/C request signal. The PCM will then remove the ground from the A/C relay. This will deactivate the A/C compressor clutch. Also, if the engine coolant reaches a temperature outside normal of its normal range, or it overheats, the ECM will deactivate the A/C clutch.

BRAKE SWITCH—ECM INPUT

When the brake light switch is activated, the ECM receives an input indicating that the brakes are being applied. After receiving this input, the ECM is used to control the speed control system. There is a Primary and a Secondary brake switch. The Secondary brake switch is closed until the brake pedal is pressed.

DESCRIPTION AND OPERATION (Continued)

DATA LINK CONNECTOR—PCM AND ECM INPUT AND OUTPUT

The 16-way data link connector (diagnostic scan tool connector) links the Diagnostic Readout Box (DRB) scan tool with the PCM and ECM. The data link connector is located under the instrument panel near the left body side cowl panel on left hand drive vehicles (Fig. 5). And near the right body side cowl panel on right hand drive vehicles.

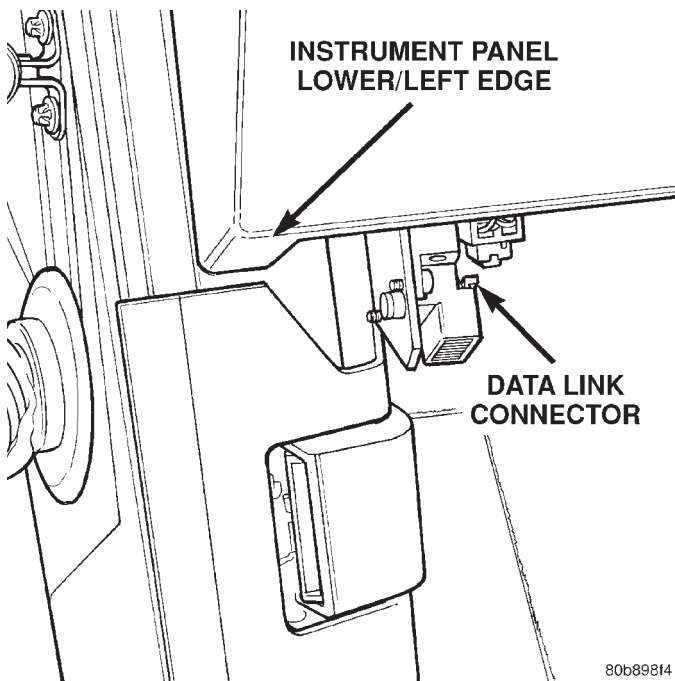

Fig. 5 Data Link Connector Location – L.H.D.

SPEED CONTROL—ECM INPUT

The speed control system provides five separate inputs to the ECM: On/Off, Set, Resume/Accel, Cancel, and Decel.. The On/Off input informs the ECM that the speed control system has been activated. The Set input informs the ECM that a fixed vehicle speed has been selected. The Resume input indicates to the ECM that the previous fixed speed is requested.

Speed control operation will start at 50 km/h–142 km/h (35–85 mph). The upper range of operation is not restricted by vehicle speed. Inputs that effect speed control operation are vehicle speed sensor and accelerator pedal position sensor.

Refer to Group 8H for further speed control information.

ASD RELAY—ECM INPUT

A 12 volt signal at this input indicates to the ECM that the ASD relay has been activated. The ASD relay is located in the PDC. The PDC is located next to the battery in the engine compartment. For the location of the relay within the PDC, refer to label on PDC cover.

This input is used only to sense that the ASD relay is energized. If the ECM does not see 12 volts (+) at this input when the ASD relay should be activated, it will set a Diagnostic Trouble Code (DTC).

FIVE VOLT POWER—ECM/PCM OUTPUT

This circuit supplies approximately 5 volts to power the Accelerator Pedal Position Sensor, and the Boost / Pressure Sensor.

ENGINE COOLANT GAUGE—PCM OUTPUT

Refer to the Instrument Panel and Gauges group for additional information.

ENGINE OIL PRESSURE GAUGE—PCM OUTPUT

Refer to the Instrument Panel and Gauges group for additional information.

GLOW PLUG LAMP—PCM OUTPUT

The Glow Plug lamp (malfunction indicator lamp) illuminates on the message center each time the ignition (key) switch is turned on. It will stay on for about two seconds as a bulb test.



Fig. 6 Glow Plug Lamp Symbol

SPEED CONTROL—PCM OUTPUTS

These two circuits control the fuel quantity actuator to regulate vehicle speed. Refer to Group 8H for Speed Control information.

AIR CONDITIONING RELAY—ECM OUTPUT

This circuit controls a ground signal for operation of the A/C clutch relay. Also refer to Air Conditioning (A/C) Controls—ECM Input for additional information.

The A/C relay is located in the Power Distribution Center (PDC). The PDC is located next to the battery in the engine compartment. For the location of the relay within the PDC, refer to label on PDC cover.

TIMING SOLENOID—ECM OUTPUT

The timing solenoid is located on the bottom of the fuel injection pump (Fig. 7).

This 12(+) volt, pulse width modulated (duty-cycle) output controls the amount of fuel timing (advance) in the fuel injection pump. The higher the duty-cycle, the lower the advance. The lower the duty-cycle, the more advanced the fuel timing.

The duty-cycle is determined by the ECM from inputs it receives from the fuel injector sensor and engine speed sensor.

DESCRIPTION AND OPERATION (Continued)

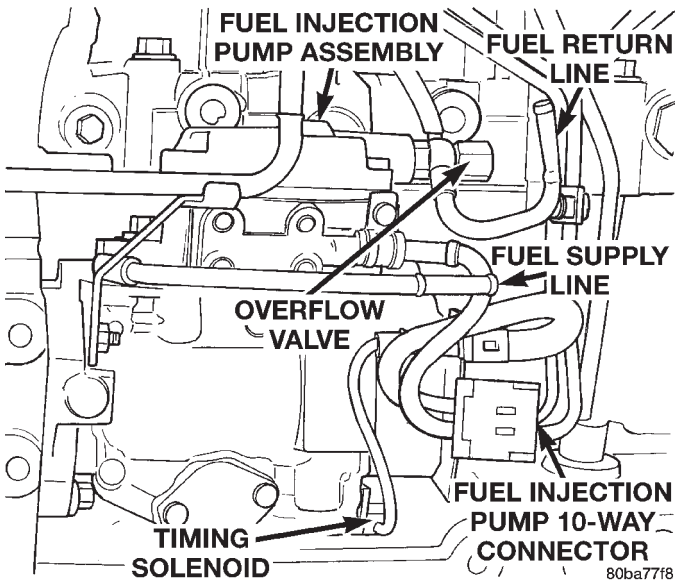

Fig. 7 Timing Solenoid

TACHOMETER—PCM OUTPUT

The PCM receives engine rpm values from the ECM controller, and then supplies engine rpm values to the Body Controller that then supplies the instrument cluster mounted tachometer (if equipped). Refer to Group 8E for tachometer information.

GLOW PLUG RELAY—ECM OUTPUT

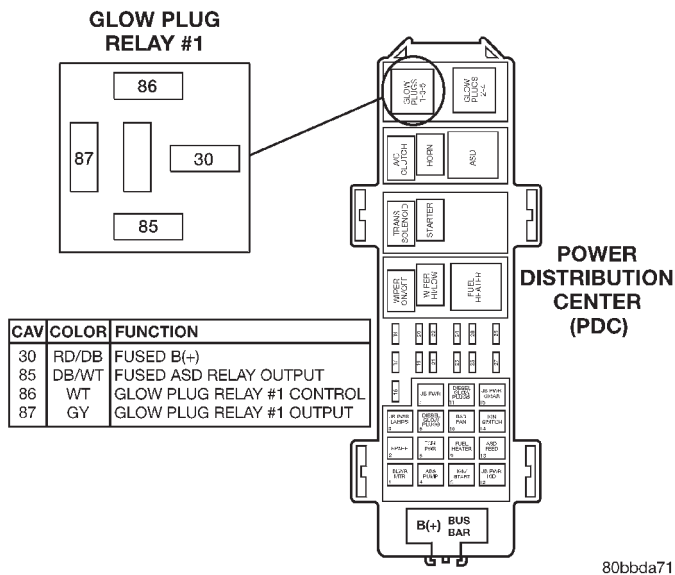

Fig. 8 Glow Plug Relay #1 Location

When the ignition (key) switch is placed in the ON position, a signal is sent to the ECM relating current engine coolant temperature. This signal is sent from the engine coolant temperature sensor.

After receiving this signal, the ECM will determine if, when and for how long a period the glow plug relay should be activated. This is done before, during

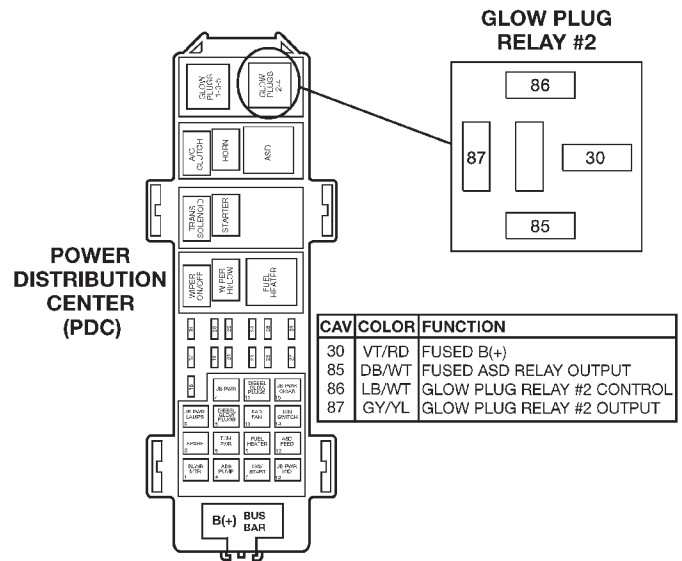

Fig. 9 Glow Plug Relay #2 Location

and after the engine is started. Whenever the glow plug relay is activated, it will control the 12V+ 100 amp circuit for the operation of the four glow plugs.

With a cold engine, the glow plug relay and glow plugs may be activated for a maximum time of 200 seconds. Refer to the following Glow Plug Control chart for a temperature/time comparison of glow plug relay operation.

In this chart, Pre-Heat and Post-Heat times are mentioned. Pre-heat is the amount of time the glow plug relay circuit is activated when the ignition (key) switch is ON, but the engine has yet to be started. Post-heat is the amount of time the glow plug relay circuit is activated after the engine is operating. The Glow Plug lamp will not be illuminated during the post-heat cycle.

GLOW PLUG CONTROL

ENGINE COOLANT TEMPERATURE KEY ON	WAIT-TO-START LAMP ON (SECONDS)	PRE-HEAT CYCLE (GLOW PLUGS ON) (SECONDS)	POST-HEAT CYCLE (SECONDS)
-30 C	15 SEC.	45 SEC.	200 SEC.
-10 C	8 SEC.	35 SEC.	180 SEC.
+10 C	6 SEC.	25 SEC.	118 SEC.
+30 C	5 SEC.	20 SEC.	70 SEC.
+40 C	4 SEC.	16 SEC.	60 SEC.
+70 C	3 SEC.	16 SEC.	20 SEC.

DESCRIPTION AND OPERATION (Continued)

GLOW PLUGS

Glow plugs are used to help start a cold or cool engine. The plug will heat up and glow to heat the combustion chamber of each cylinder. An individual plug is used for each cylinder. Each plug is threaded into the cylinder head above the fuel injector (Fig. 10).

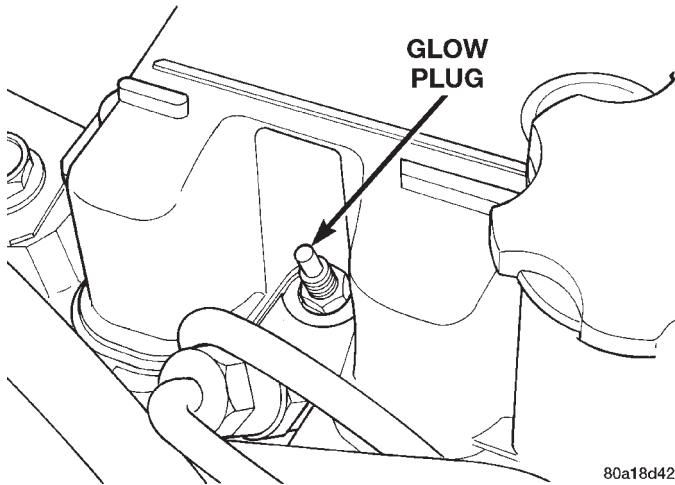

Fig. 10 Glow Plug

Each plug will momentarily draw approximately 25 amps of electrical current during the initial key-on cycle. This is on a cold or cool engine. After heating, the current draw will drop to approximately 9–12 amps per plug.

Total momentary current draw for all four plugs is approximately 100 amps on a cold engine dropping to a total of approximately 40 amps after the plugs are heated.

Electrical operation of the glow plugs are controlled by the glow plug relay. Refer to the previous Glow Plug Relay—ECM Output for additional information.

ELECTRIC VACUUM MODULATOR (EVM)—ECM OUTPUT

This circuit controls operation of the Electric Vacuum Modulator (EVM). The EVM controls operation of the EGR valve.

Refer to Group 25, Emission Control System for information. See Electric Vacuum Modulator.

DIAGNOSIS AND TESTING**DIESEL DIAGNOSTICS**

The ECM controllers perform engine off diagnostic tests, which may be heard for about 60 seconds after turning the key off.

ASD RELAY TEST

To perform a test of the relay and its related circuitry, refer to the DRB scan tool. To test the relay only, refer to Relays—Operation/Testing in this section of the group.

Diagnostic Trouble Codes: Refer to On-Board Diagnostics in Group 25, Emission Control System for a list of Diagnostic Trouble Codes (DTC's) for certain fuel system components.

ENGINE SPEED SENSOR TEST

To perform a test of the engine speed sensor and its related circuitry, refer to the 3.1L Powertrain Diagnostic Procedures Manual.

Diagnostic Trouble Codes: Refer to On-Board Diagnostics in Group 25, Emission Control System for a list of Diagnostic Trouble Codes (DTC's) for certain fuel system components.

ENGINE COOLANT TEMPERATURE SENSOR TEST

The sensor is located on the side of cylinder head near the rear of fuel injection pump (Fig. 11).

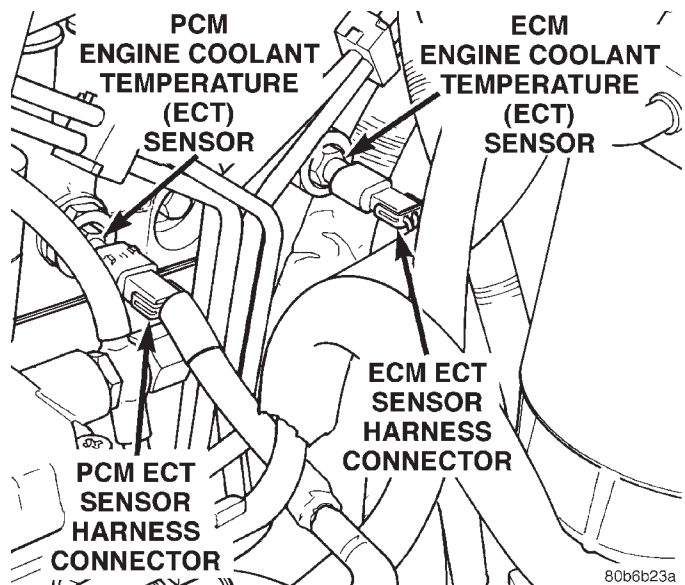

Fig. 11 Engine Coolant Temperature Sensor Location

For a list of Diagnostic Trouble Codes (DTC's) for certain fuel system components, refer to On-Board Diagnostics in Group 25, Emission Control System. To test the sensor only, refer to the following:

(1) Disconnect wire harness connector from coolant temperature sensor.

(2) Test the resistance of the sensor with a high input impedance (digital) volt-ohmmeter. The resistance (as measured across the sensor terminals) should be less than 1340 ohms with the engine warm. Refer to the following Sensor Resistance

DIAGNOSIS AND TESTING (Continued)

(OHMS) chart. Replace the sensor if it is not within the range of resistance specified in the chart.

SENSOR RESISTANCE (OHMS)

TEMPERATURE		RESISTANCE (OHMS)	
C	F	MIN	MAX
-40	-40	291,490	381,710
-20	-4	85,850	108,390
-10	14	49,250	61,430
0	32	29,330	35,990
10	50	17,990	21,810
20	68	11,370	13,610
25	77	9,120	10,880
30	86	7,370	8,750
40	104	4,900	5,750
50	122	3,330	3,880
60	140	2,310	2,670
70	158	1,630	1,870
80	176	1,170	1,340
90	194	860	970
100	212	640	720
110	230	480	540
120	248	370	410

J928D-4

(3) Test continuity of the wire harness. Do this between the ECM wire harness connector and the sensor connector terminal. Also test continuity of wire harness to the sensor connector terminal. Refer to Group 8W for wiring connector and circuitry information. Repair the wire harness if an open circuit is indicated.

(4) After tests are completed, connect electrical connector to sensor.

GLOW PLUG TEST

Hard starting or a rough idle after starting may be caused by one or more defective glow plugs. Before testing the glow plugs, a test of the glow plug relays should be performed. This will ensure that 12V+ is available at the plugs when starting the engine. Refer to the Glow Plug Relay Test for information.

For accurate test results, the glow plugs should be removed from the engine. The plugs must be checked when cold. **Do not check the plugs if the engine has recently been operated. If plugs are checked when warm, incorrect amp gauge readings will result.**

Use Churchill Glow Plug Tester DX.900 or an equivalent (Fig. 12) for the following tests. This tester is equipped with 4 timer lamps.

(1) Remove the glow plugs from the engine. Refer to Glow Plug Removal/Installation.

(2) Attach the red lead of the tester to the 12V+ (positive) side of the battery.

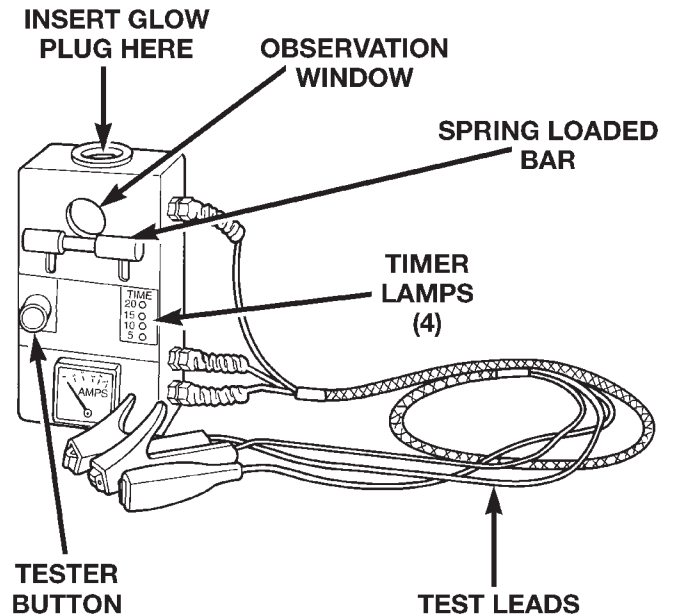

80a0c62d

Fig. 12 Typical Glow Plug Tester

(3) Attach the black lead of the tester to the 12V- (negative) side of the battery.

(4) Fit the glow plug into the top of the tester and secure it with the spring loaded bar (Fig. 12).

(5) Attach the third lead wire of the tester to the electrical terminal at the end of the glow plug.

(6) When performing the test, the tester button (Fig. 12) should be held continuously without release for 20 seconds as indicated by the 4 timer lamps. Each illuminated lamp represents a 5 second time lapse.

(a) Press and hold the tester button (Fig. 12) and note the amp gauge reading. The gauge reading should indicate a momentary, initial current draw (surge) of approximately 25 amps. After the initial surge, the amp gauge reading should begin to fall off. The glow plug tip should start to glow an orange color after 5 seconds. If the tip did not glow after 5 seconds, replace the glow plug. Before discarding the glow plug, check the position of the circuit breaker on the bottom of the plug tester. It may have to be reset. Reset if necessary.

(b) Continue to hold the tester button while observing the amp gauge and the 4 timer lamps. When all 4 lamps are illuminated, indicating a 20 second time lapse, the amp gauge reading should indicate a 9-12 amp current draw. If not, replace the glow plug. Refer to Glow Plug Removal/Installation.

(7) Check each glow plug in this manner using one 20 second cycle. If the glow plug is to be retested, it must first be allowed to cool to room temperature.

DIAGNOSIS AND TESTING (Continued)

WARNING: THE GLOW PLUG WILL BECOME EXTREMELY HOT (GLOWING) DURING THESE TESTS. BURNS COULD RESULT IF IMPROPERLY HANDLED. ALLOW THE GLOW PLUG TO COOL BEFORE REMOVING FROM TESTER.

(8) Remove the glow plug from the tester.

GLOW PLUG RELAY TEST

The glow plug relay is located in the Power Distribution Center (PDC) (Fig. 13) (Fig. 14).

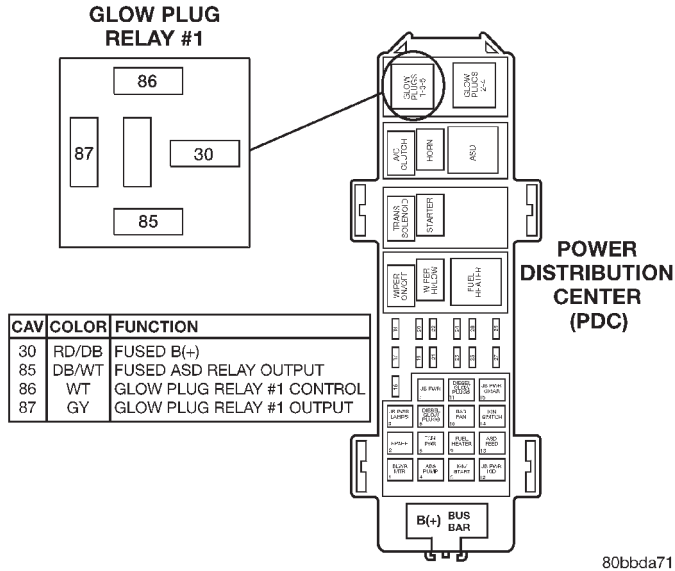

Fig. 13 Glow Plug Relay #1 Location

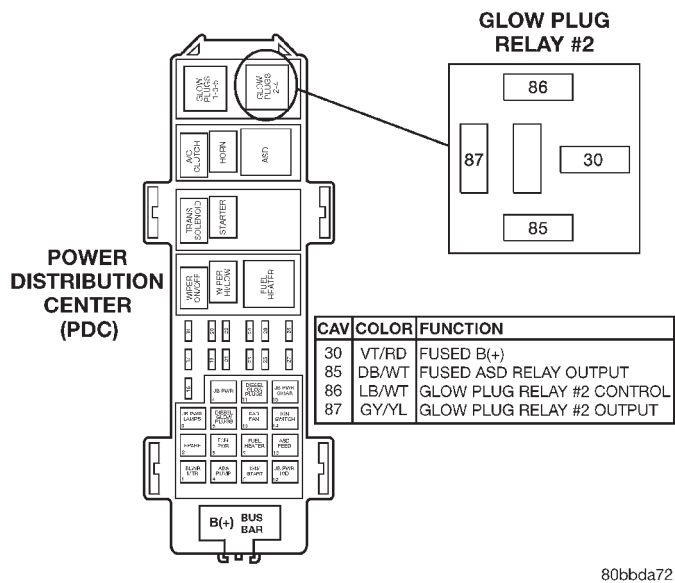

Fig. 14 Glow Plug Relay #2 Location

When the ignition (key) switch is placed in the ON position, a signal is sent to the ECM relating current engine coolant temperature. This signal is sent from the engine coolant temperature sensor.

After receiving this signal, the ECM will determine if, when and for how long a period the glow plug relay should be activated. This is done before, during and after the engine is started. Whenever the glow plug relay is activated, it will control the 12V+ 100 amp circuit for the operation of the four glow plugs.

The Glow Plug lamp is tied to this circuit. Lamp operation is also controlled by the ECM.

With a cold engine, the glow plug relay and glow plugs may be activated for a maximum time of 200 seconds. Refer to the Glow Plug Control chart for a temperature/time comparison of glow plug relay operation.

In this chart, Pre-Heat and Post-Heat times are mentioned. Pre-heat is the amount of time the glow plug relay circuit is activated when the ignition (key) switch is ON, but the engine has yet to be started. Post-heat is the amount of time the glow plug relay circuit is activated after the engine is operating. The Glow Plug lamp will not be illuminated during the post-heat cycle.

TESTING:

Disconnect and isolate the electrical connectors (Fig. 15) at all four glow plugs. With the engine cool or cold, and the key in the ON position, check for 10–12 volts + at each electrical connector. 10–12 volts + should be at each connector whenever the ECM is operating in the pre-heat or post-heat cycles (refer to the following Glow Plug Control chart). **Be very careful not to allow any of the four disconnected glow plug electrical connectors to contact a metal surface. When the key is turned to the ON position, approximately 100 amps at 12 volts is supplied to these connectors.** If 10–12 volts + is not available at each connector, check continuity of wiring harness directly to the relay. If continuity is good directly to the relay, the fault is either with the relay or the relay input from the ECM. To test the relay only, refer to Relays—Operation/Testing in this section of the group. If the relay test is good, refer to the DRB scan tool.

Diagnostic Trouble Codes: Refer to On-Board Diagnostics in Group 25, Emission Control System for a list of Diagnostic Trouble Codes (DTC's) for certain fuel system components.

RELAYS—OPERATION/TESTING

The following description of operation and tests apply only to the ASD and other relays . The terminals on the bottom of each relay are numbered.

OPERATION

- Terminal number 30 is connected to battery voltage. For both the ASD and other relays, terminal 30 is connected to battery voltage at all times.

DIAGNOSIS AND TESTING (Continued)

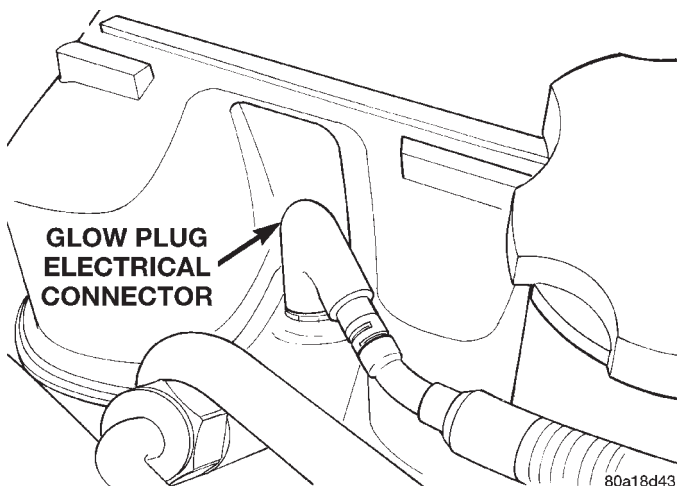

Fig. 15 Wiring Connection at Glow Plug

GLOW PLUG CONTROL

ENGINE COOLANT TEMPERATURE KEY ON	WAIT-TO-START LAMP ON (SECONDS)	PRE-HEAT CYCLE (GLOW PLUGS ON) (SECONDS)	POST-HEAT CYCLE (SECONDS)
-30 C	15 SEC.	45 SEC.	200 SEC.
-10 C	8 SEC.	35 SEC.	180 SEC.
+10 C	6 SEC.	25 SEC.	118 SEC.
+30 C	5 SEC.	20 SEC.	70 SEC.
+40 C	4 SEC.	16 SEC.	60 SEC.
+70 C	3 SEC.	16 SEC.	20 SEC.

80a0c517

- The ECM grounds the coil side of the relay through terminal number 85.
- Terminal number 86 supplies voltage to the coil side of the relay.
- When the PCM de-energizes the ASD and other relays, terminal number 87A connects to terminal 30. This is the Off position. In the off position, voltage is not supplied to the rest of the circuit. Terminal 87A is the center terminal on the relay.
- When the ECM energizes the ASD and other relays, terminal 87 connects to terminal 30. This is the On position. Terminal 87 supplies voltage to the rest of the circuit.

TESTING

The following procedure applies to the ASD and other relays.

- (1) Remove relay from connector before testing.

(2) With the relay removed from the vehicle, use an ohmmeter to check the resistance between terminals 85 and 86. The resistance should be between 75 ± 5 ohms.

(3) Connect the ohmmeter between terminals 30 and 87A. The ohmmeter should show continuity between terminals 30 and 87A.

(4) Connect the ohmmeter between terminals 87 and 30. The ohmmeter should not show continuity at this time.

(5) Connect one end of a jumper wire (16 gauge or smaller) to relay terminal 85. Connect the other end of the jumper wire to the ground side of a 12 volt power source.

(6) Connect one end of another jumper wire (16 gauge or smaller) to the power side of the 12 volt power source. **Do not attach the other end of the jumper wire to the relay at this time.**

WARNING: DO NOT ALLOW OHMMETER TO CONTACT TERMINALS 85 OR 86 DURING THIS TEST.

(7) Attach the other end of the jumper wire to relay terminal 86. This activates the relay. The ohmmeter should now show continuity between relay terminals 87 and 30. The ohmmeter should not show continuity between relay terminals 87A and 30.

(8) Disconnect jumper wires.

(9) Replace the relay if it did not pass the continuity and resistance tests. If the relay passed the tests, it operates properly. Check the remainder of the ASD and other relay circuits. Refer to group 8W, Wiring Diagrams.

BOOST / PRESSURE SENSOR

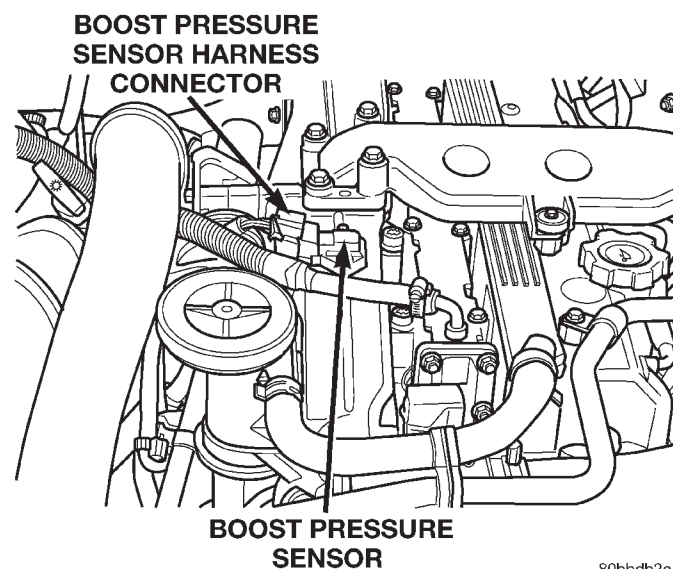

Fig. 16 Boost Pressure Sensor Location

DIAGNOSIS AND TESTING (Continued)

If the boost pressure sensor fails, the PCM records a DTC into memory and continues to operate the engine in one of the three “limp-in” modes. When the PCM is operating in this mode, a loss of power will be present, as if the turbocharger was not operating. The best method for diagnosing faults with the boost pressure sensor is with the DRB III scan tool. **Diagnostic Trouble Codes:** Refer to On-Board Diagnostics in Group 25, Emission Control System for a list of Diagnostic Trouble Codes (DTC's) for certain fuel system components.

VEHICLE SPEED SENSOR TEST

To perform a test of the sensor and its related circuitry, refer to DRB scan tool.

Diagnostic Trouble Codes: Refer to On-Board Diagnostics in Group 25, Emission Control System for a list of Diagnostic Trouble Codes (DTC's) for certain fuel system components.

DIAGNOSTIC TROUBLE CODES

For a list of Diagnostic Trouble Codes (DTC's), refer to Group 25, Emission Control System for information. See On-Board Diagnostics.

REMOVAL AND INSTALLATION

ASD RELAY

The ASD relay is located in the PDC. For the location of the relay within the PDC, refer to label on PDC cover.

A/C CLUTCH RELAY

The A/C clutch relay is located in the PDC. For the location of the relay within the PDC, refer to label on PDC cover.

ENGINE SPEED SENSOR

The engine speed sensor is mounted to the top of the transmission adapter plate near the rear of the engine block (Fig. 17).

REMOVAL

- (1) Remove the intercooler inlet hose from the turbocharger (Fig. 18).
- (2) Disconnect the breather hose from the fresh air inlet tube (Fig. 18).
- (3) Unclip the air filter cover and remove the fresh air inlet tube from the turbocharger (Fig. 18). Remove the assembly from the vehicle.
- (4) Remove the EGR vacuum supply hose from the EGR valve (Fig. 19).
- (5) Unclip the wire harness from the coolant supply lines (Fig. 19).

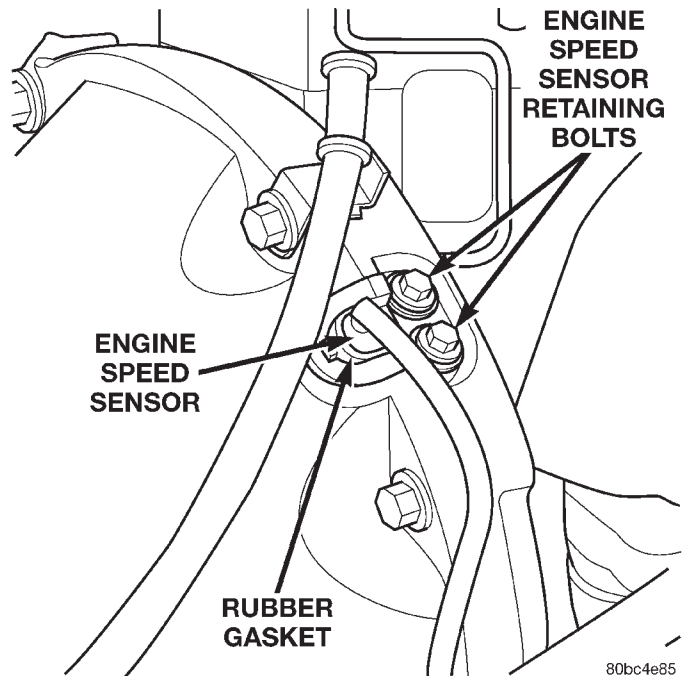

Fig. 17 Engine Speed Sensor Position & Orientation

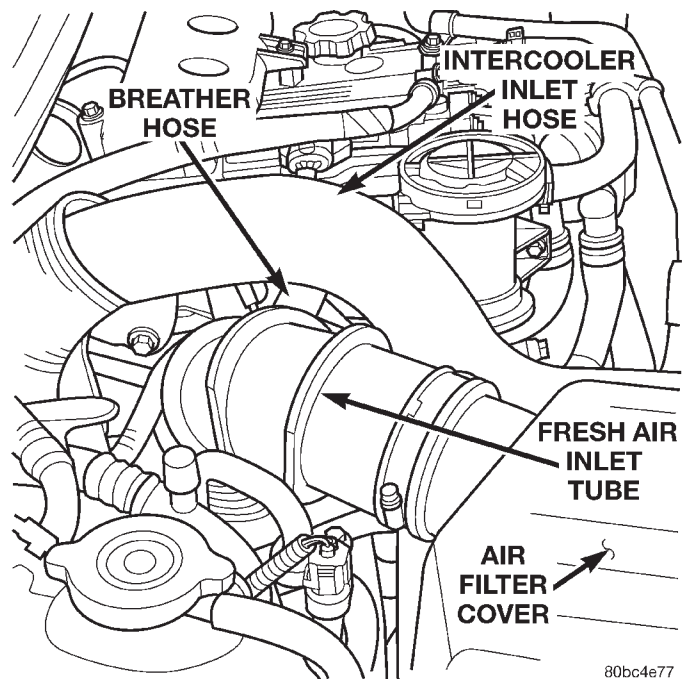

Fig. 18 Air Intake Hoses

- (6) Remove the (2) EGR valve / coolant supply line retaining bolts (Fig. 19).
- (7) Remove the coolant supply line support bracket bolt from the water pump housing.
- (8) Remove the oil separator retaining bolts.
- (9) Disconnect the crankcase vapor supply and return hoses and remove the oil separator from the vehicle.

REMOVAL AND INSTALLATION (Continued)

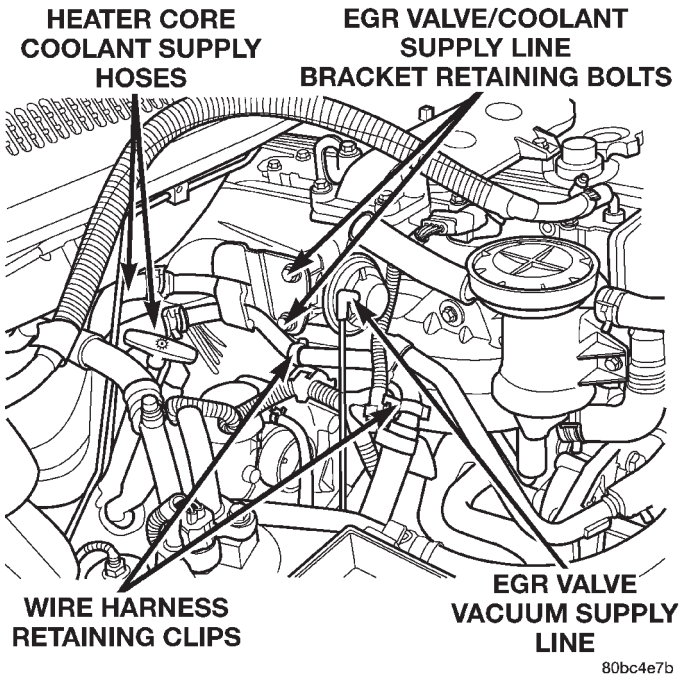

Fig. 19 3.1 L Diesel Engine

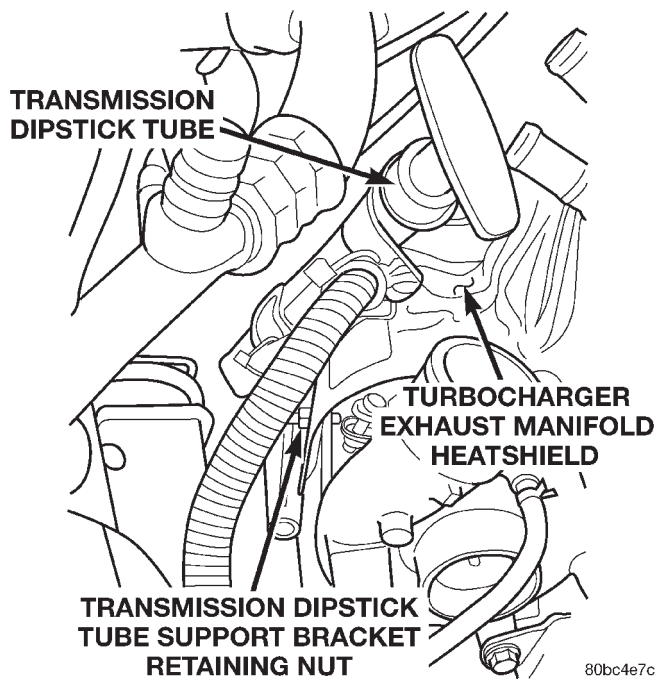

Fig. 20 Transmission Dipstick Tube Support Bracket

(10) Remove the transmission dipstick tube support bracket nut from the turbocharger heatshield (Fig. 20).

WARNING: Heatshield is very sharp. Wear gloves to prevent injury.

(11) Remove the exhaust manifold / turbocharger heatshield retaining bolts.

(12) Position the coolant line assembly out of the way and remove the heatshield from the vehicle.

(13) Working behind the exhaust manifold, disconnect the engine speed sensor electrical connector (Fig. 21).

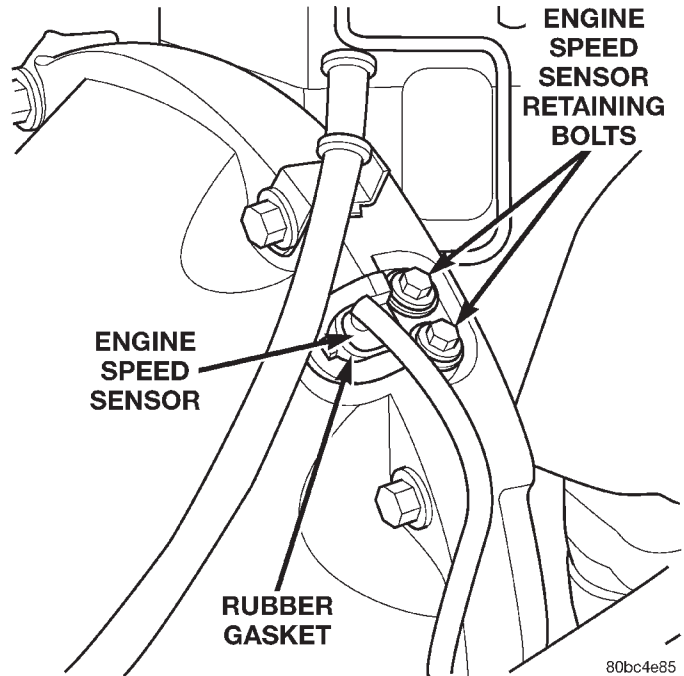

Fig. 21 Engine Speed Sensor

(14) Remove the (2) engine speed sensor retaining bolts (Fig. 21).

(15) Remove the engine speed sensor from the vehicle.

INSTALLATION

(1) Install the engine speed sensor in the transmission adapter plate.

(2) Install the (2) engine speed sensor retaining bolts (Fig. 22). Torque the bolts to 11 N·m (97 in. lbs.).

(3) Connect the engine speed sensor electrical connector (Fig. 22).

WARNING: Heatshield is very sharp. Wear gloves to prevent injury.

(4) Install the exhaust manifold heatshield. Torque bolts to 11 N·m (97 in. lbs.).

(5) Install the transmission dipstick tube support bracket retaining nut on the turbocharger heatshield (Fig. 23). Torque the nut to 11 N·m (97 in. lbs.).

(6) Install the coolant line assembly on the engine. Torque the (3) retaining bolts to 27 N·m (20 ft. lbs.) (Fig. 24).

(7) Connect the crankcase vapor supply and return hoses on the oil separator.

(8) Install the oil separator retaining bolts.

REMOVAL AND INSTALLATION (Continued)

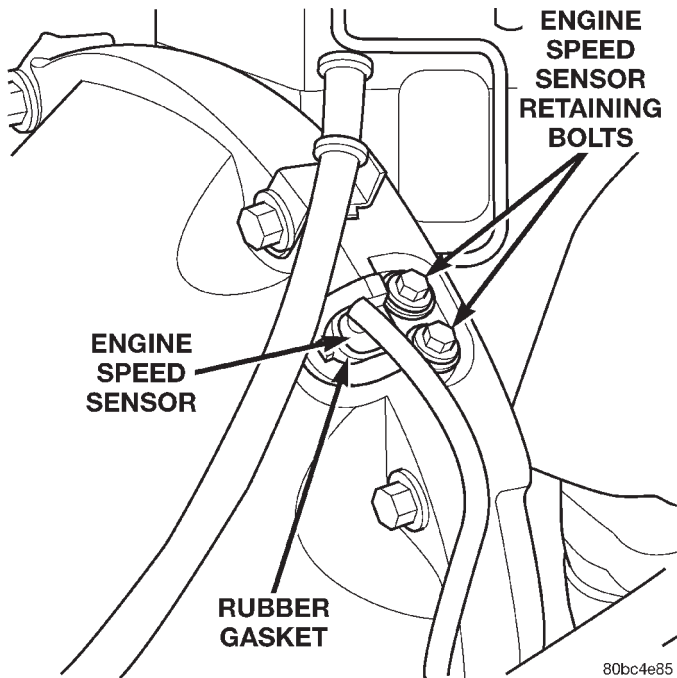

Fig. 22 Engine Speed Sensor

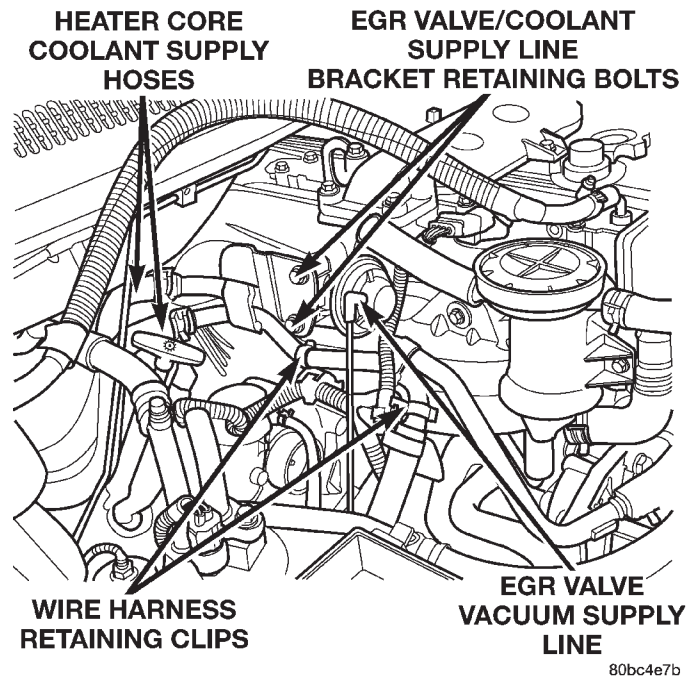

Fig. 24 3.1L Diesel Engine

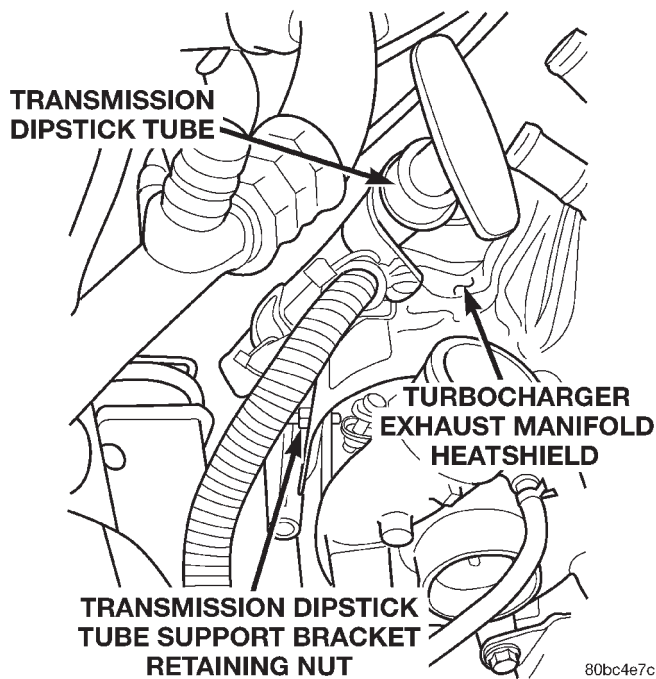

Fig. 23 Transmission Dipstick Tube Support Bracket

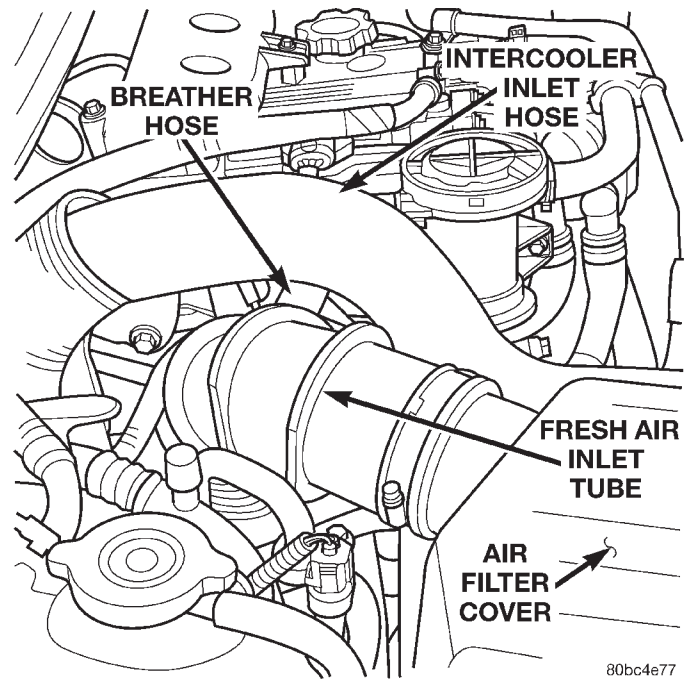

Fig. 25 Air Intake Hoses

- (9) Clip the wire harness on the coolant supply lines (Fig. 24).
- (10) Install the EGR vacuum supply hose on the EGR valve.
- (11) Install the fresh air inlet tube assembly on the turbocharger. Clip the air filter cover in position and connect the breather hose (Fig. 25).
- (12) Install the intercooler inlet hose on the turbocharger (Fig. 25).

- (13) Check the transmission fluid level and top off if necessary.
- (14) Connect the negative battery cable.
- (15) Start the engine and check for leaks.

ENGINE COOLANT TEMPERATURE SENSOR

The sensors are located on the side of cylinder head near the rear of fuel injection pump.

REMOVAL AND INSTALLATION (Continued)

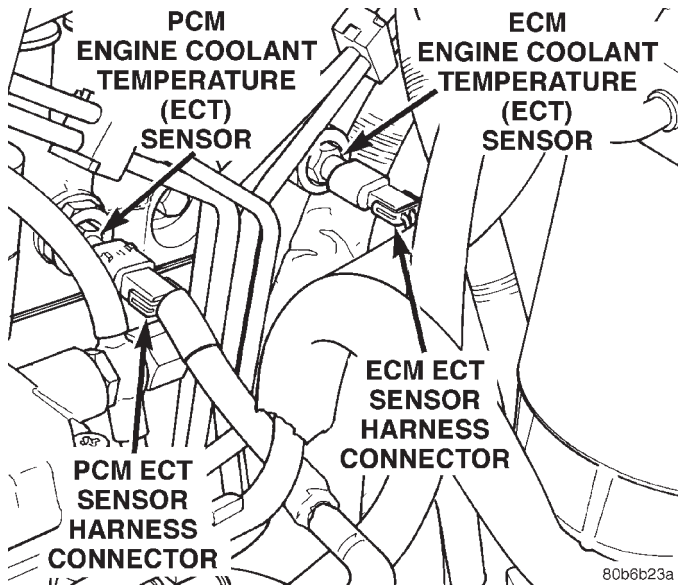

Fig. 26 Engine Coolant Temperature Sensors

REMOVAL

WARNING: HOT, PRESSURIZED COOLANT CAN CAUSE INJURY BY SCALDING. COOLING SYSTEM MUST BE PARTIALLY DRAINED BEFORE REMOVING THE COOLANT TEMPERATURE SENSOR. REFER TO GROUP 7, COOLING.

- (1) Partially drain the cooling system. Refer to Group 7, Cooling System for the procedure.
- (2) Disconnect electrical connector from sensor.
- (3) Remove sensor from cylinder head.

INSTALLATION

- (1) Install a new copper gasket on sensor, if equipped.
- (2) Install sensor in cylinder head.
- (3) Torque the sensor to 8 N·m (70 in. lbs.).
- (4) Install electrical connector on sensor.
- (5) Replace any lost engine coolant. Refer to Group 7, Cooling System for the procedure.

GLOW PLUGS

The glow plugs are located above each fuel injector (Fig. 27). Four individual plugs are used.

REMOVAL

- (1) Disconnect the negative battery cable at the battery.

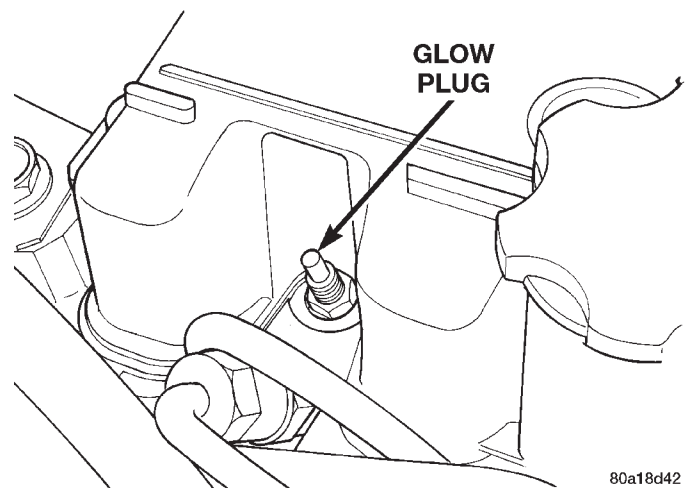

Fig. 27 Glow Plug

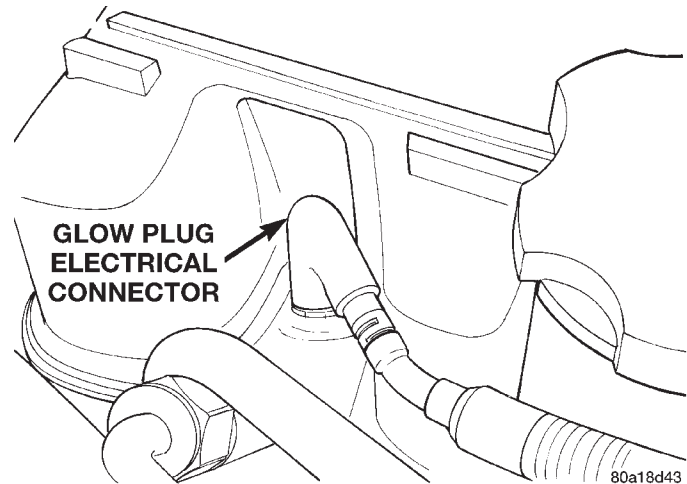

Fig. 28 Glow Plug Electrical Connector

- (2) Clean the area around the glow plug with compressed air before removal.
- (3) Disconnect electrical connector (Fig. 28) at glow plug.
- (4) Remove the glow plug (Fig. 27) from cylinder head.

INSTALLATION

- (1) Apply high-temperature anti-seize compound to glow plug threads before installation.
- (2) Install the glow plug into the cylinder head. Tighten to 14 N·m (123 in. lbs.) torque.
- (3) Connect battery cable to battery.

SPECIFICATIONS

GLOW PLUG CURRENT DRAW

Initial Current Draw: Approximately 22–25 amps per plug.

After 20 seconds of operation: Approximately 9–12 amps per plug.

TORQUE CHART—3.1L DIESEL

DESCRIPTION	TORQUE
Accelerator Pedal Bracket Mounting Nuts.....	5 N•m (46 in. lbs.)
Banjo-Type Fittings.....	19 N•m (14 ft. lbs.)
Engine Coolant Temperature Sensor.....	8 N•m (70 in. lbs.)
Engine Speed Sensor Bolts.....	11N•m (97 in. lbs.)
Fuel Hose (Tube) Clamps For Rubber Hose.....	2 N•m (20 in. lbs.)
Fuel Injector.....	70 N•m (52 ft. lbs.)
Fuel Injector Line At Injector.....	19 N•m (168 in. lbs.)
Fuel Injector Line At Injector Pump.....	19N•m (168 in. lbs.)

DESCRIPTION	TORQUE
Fuel Injection Pump Mounting Nuts.....	27N•m (241 in. lbs.)
Fuel Injection Pump Drive Gear Nut.....	86 N•m (64 ft. lbs.)
Fuel Line Clamp Bracket Bolts.....	24 N•m (18 ft. lbs.)
Fuel Tank Nuts.....	11 N•m (100 in. lbs.)
Glow Plugs.....	14 N•m (123 in. lbs.)
Powertrain Control Module Mounting Bolts.....	1 N•m (9 in. lbs.)
Throttle Position Sensor Mounting Bolts.....	7 N•m (60 in. lbs.)
Vehicle Speed Sensor Mounting Bolt.....	3 N•m (26 in. lbs.)

80bceaa2

Torque Specifications

